

SMC (Surface Mount Compatible) types, 2.00 mm pitch

Page

<i>harbus® HM+</i> connector system – general information	01.02
Solder requirements	01.03
SMC connectors	01.04
 <i>Angled female connectors*</i>	
Type A	01.05
Type B	01.06
Type AB	01.07
Type C	01.08

harbus® HM+

* Technical characteristics see chapter 00

The continuing trend towards miniaturisation has revolutionised the assembly of electronic components. For the past 15 years, most components have been secured directly to the pcb surface by means of Surface Mount Technology (SMT). By dispensing with drilled holes on the pcb, a space saving of up to 70 percent is achieved.

Today, typical components such as ICs, resistors, capacitors, inductors, and connectors with straight terminal pins are almost exclusively fitted using SMD (Surface Mount Device) technology in mass production. In contrast, angled SMD connectors at the edge of the board have not been successful because of tolerance problems (co-planarity) and stresses during mating.

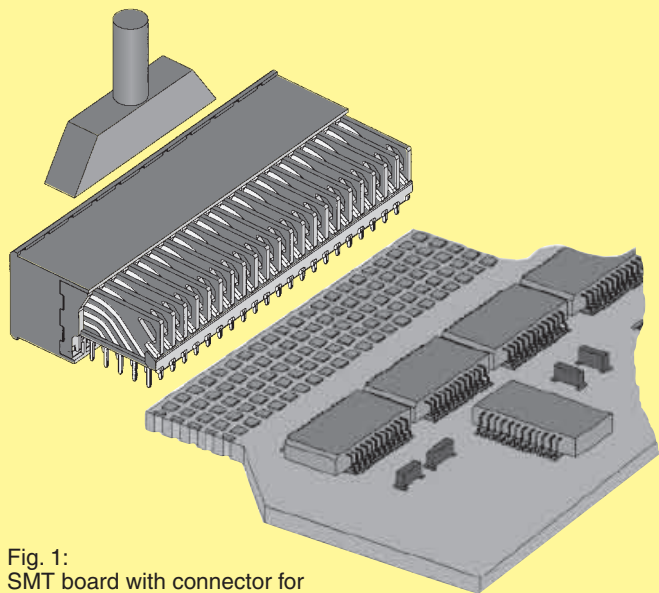

Fig. 1:
SMT board with connector for
"Pin in Hole Intrusive Reflow" assembly

"Pin in Hole Intrusive Reflow"*

In this process, the connector is inserted into plated through holes in a comparable way to conventional component mounting. All other components can be assembled on the pcb surface.

The components are positioned using pick-and-place machines. These automatic assembly machines differ according to whether the components are small, lightweight or bulky. Connectors, compared to ICs, are considered bulky (odd form). They are more difficult to grip, due to their comparatively heavy weight and larger size. But machines for odd form components, provide the higher insertion power, necessary to fit the components into pcb holes, which are filled with solder paste. Generally modern

SMC production lines are equipped with both types of machine. Therefore the "Pin in Hole Intrusive Reflow" process entails no extra investment costs for the user.

Conventional assembly process:

1. Application of solder paste
2. Positioning the components
3. Positioning odd form components
4. Reflow soldering
5. Pressing in or partially dip soldering the connector at the board edge
6. Quality inspection

"Pin in Hole Intrusive Reflow" assembly:

1. Application of solder paste
2. Positioning the components
3. Positioning odd form components
4. Reflow soldering
5. Pressing in or partially dip soldering the connector at the board edge
6. Quality inspection

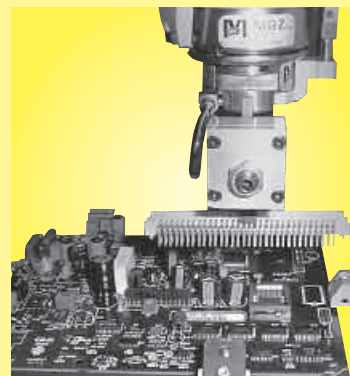

Fig. 2:
Pick-and-place machine for
odd form components
(Courtesy of JOT Automation GmbH)

* Also known as Pin-in-Paste or Through Hole Reflow (THR)

harbus® HM+ connector was designed for Pin in Hole Intrusive Reflow with features like an inspection friendly black colour, tape and reel packaging for automated handling and it is self retaining on pcb. The design – moulded from high temperature resistant material – ensures good heat distribution, so that current solder temperature profiles can be used. The special material of the insulation body withstands also the higher temperatures of lead free soldering.

Advantages for using harbus® HM+ connectors are:

- Partial dip soldering or press fitting is no longer required
- High mechanical stability
- Complete compatibility with Surface Mount Technology
- Savings through integration into the automated assembly process
- Reduced floor space in the production plant

Application of solder paste

Before the components are assembled, solder paste is applied to all the solder pads and the plated through holes. Usually a screen printing process is used for this purpose. A squeegee moves across the pcb, which is masked with screens and presses the solder paste into all unmasked areas. A good solder joint is basically determined by the amount of the applied solder paste. Only a few parameters (illustrated on the right) will lead to the right quantity.

As an alternative to screen printing, the solder paste can be applied by means of a dispenser. A high-precision robot moves the dispenser to all required positions on the pcb. The dispensing method is particularly suitable for small pcb's or applications which demand high precision and flexibility in dispensing volumes.

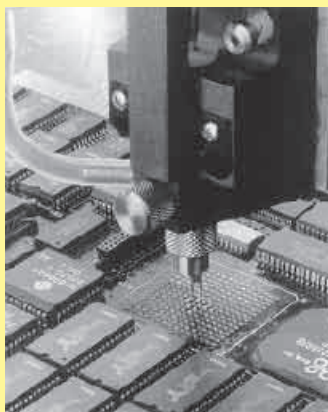

Fig. 3: Dispenser in operation

Solder paste volume

There are numerous scientific studies dealing with calculation of the required quantity of solder paste. These studies use various parameters, e.g. the shrinking factor of the paste during soldering or the thickness of the screens used for masking the pcb. Since such calculation methods are complicated to apply, the following rule of thumb has proved valuable in practice:

$$V_{\text{Paste}} = 2(V_H - V_P)$$

in which:

V_{Paste} = Required volume of solder paste

V_H = Volume of the plated through hole

V_P = Volume of the connector termination in the hole

Comment: the multiplier “2” compensates for solder paste shrinkage during soldering. For this purpose, it was assumed that 50 % of the paste consists of the actual solder, the other 50 % being soldering aids.

Requirements for the solder connection

At the beginning of a new production batch, the process parameters, such as quantity of solder paste and soldering temperature, can be set by interpreting simple cross-sections of the soldered connection. A reliable measure for achieving optimum parameters is the quantity of solder required to fill the hole. In soldered connections of high quality, the holes are filled to between 75 % and 100 %.

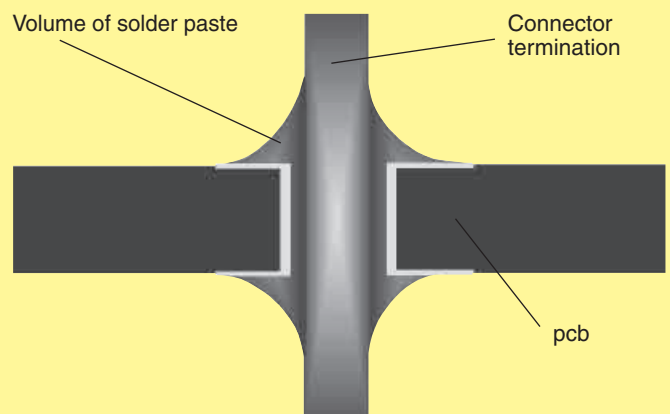

Fig. 4: Plated through hole with connector termination

Requirements for SMC connectors

Conventional SMC (Surface Mount Compatible) connectors have to withstand temperatures of up to 225°C in the reflow oven for 10 to 15 seconds. Industry is moving towards lead free soldering with temperatures in the range of 235°C up to 260°C. Peak values might be above this level. Therefore, the moulding must be made from a dimensionally stable plastic which expands at the same rate as the pcb material when subjected to heat.

For the reflow soldering homogeneous heat distribution and unimpeded access for convection heat is important to reach all the solder joints. This is particularly necessary when dealing with the higher reflow temperatures of lead free soldering.

The HARTING design of the *harbus® HM+* connector meets this requirement. It guarantees good heat distribution to all soldered joints. Even contact row "a", which is most hidden by the nature of design, is heating up during the known soldering process.

With this new concept, hard metric 2 mm *harbus® HM+* connectors can now be fully integrated into the economic reflow soldering process.



Fig. 5: The HARTING connector can be mounted in a tape ready for automatic placement.

HARTING SMC technology

HARTING offers its customers a complete system concept for integrating SMC technology into existing production lines. In addition to *harbus® HM+* connectors we manufacture a wide range of SMC connectors, e. g. 3- and 5-row connectors, in compliance with IEC 60 603-2, D-Sub connectors in compliance with IEC 60 807 and connectors from the har-mik® series with contact spacing of 1.27 millimetres. In addition, HARTING supports the market with packaging and processing concepts, which have been developed in collaboration with renowned manufacturers of SMC soldering and assembly plants.

You will find more detailed information in our SMC catalogue, as well as in our DIN 41 612 connectors catalogue.

harbus® HM+ connectors are ideally suited for fully automated assembly.

The benefits are:

- Compatible to conventional press fit connectors
- High mechanical stability
- Compatible to existing board layout
- Cost reduction by process step elimination
- Lead free soldering process

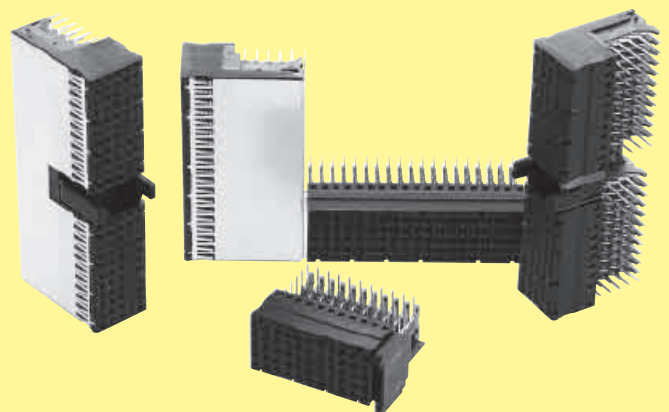
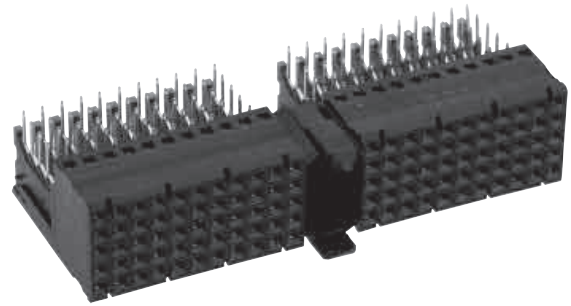
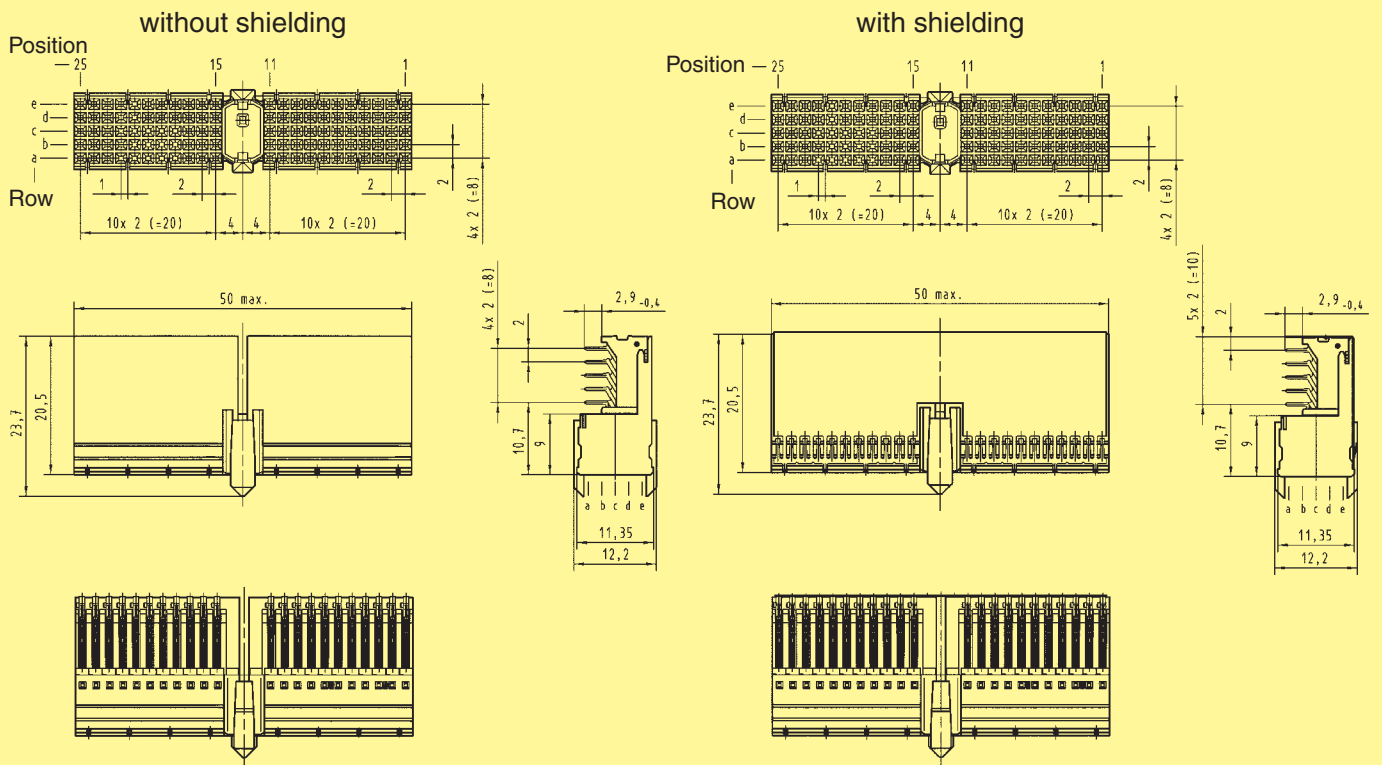

Fig. 6: *har-bus HM+* connector



Female connectors, angled

Identification	No. of contacts	Contact length [mm] termination side	Part number
Type A	110	2.5	17 21 110 1801
Type A with upper shield	110	2.5	17 21 110 1802



Board drillings

Diameter of drillings: $\varnothing 0.7 \pm 0.025$ mm
 Diameter of plated through holes: $\varnothing 0.6 \pm 0.050$ mm

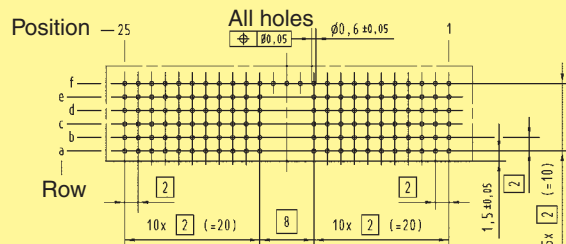
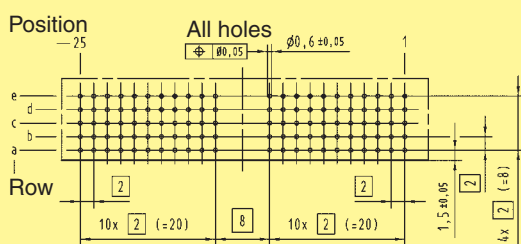

Dimensions [mm]

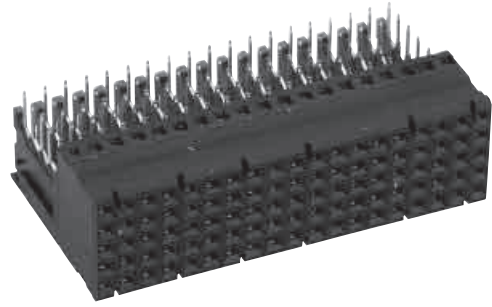

Female connectors, angled

Identification	No. of contacts	Contact length [mm] termination side	Part number
Type B ₁₉	95	2.5	17 25 095 1801
Type B ₁₉ with upper shield	95	2.5	17 25 095 1802
Type B ₂₂	110	2.5	17 24 110 1801
Type B ₂₂ with upper shield	110	2.5	17 24 110 1802
Type B ₂₅	125	2.5	17 22 125 1801
Type B ₂₅ with upper shield	125	2.5	17 22 125 1802

without shielding

with shielding

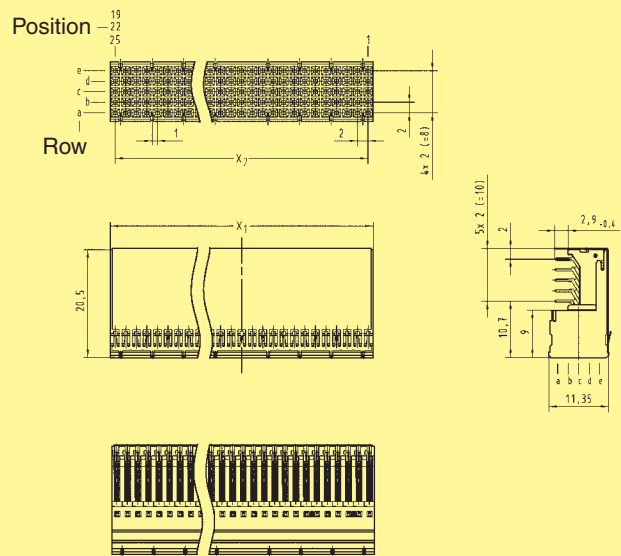
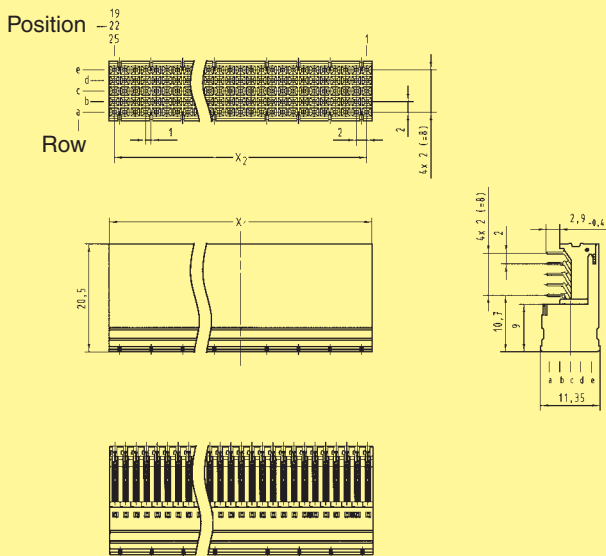

Board drillings

Diameter of drillings: $\varnothing 0.7 \pm 0.025$ mm
 Diameter of plated through holes: $\varnothing 0.6 \pm 0.050$ mm

Contact positions	X ₁	X ₂
19	38	18 x 2 (= 36)
22	44	21 x 2 (= 42)
25	50	24 x 2 (= 48)

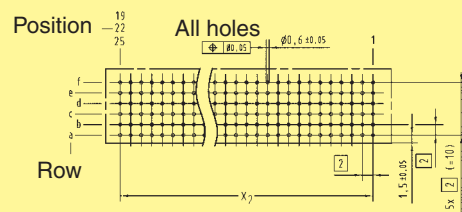
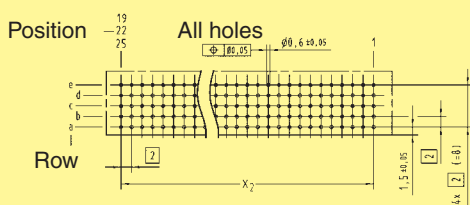

Dimensions [mm]

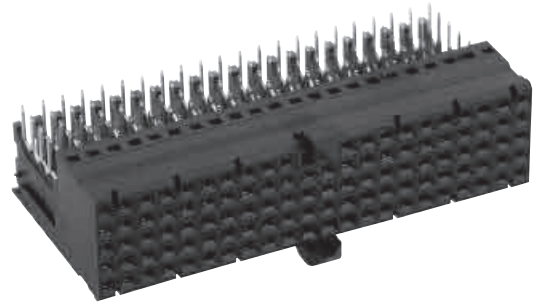

Female connectors, angled

Identification	No. of contacts	Contact length [mm]	
		termination side	Part number
Type AB ₁₉	95	2.5	17 33 095 1801
Type AB ₁₉ with upper shield	95	2.5	17 33 095 1802
Type AB ₂₂	110	2.5	17 34 110 1801
Type AB ₂₂ with upper shield	110	2.5	17 34 110 1802
Type AB ₂₅	125	2.5	17 35 125 1801
Type AB ₂₅ with upper shield	125	2.5	17 35 125 1802

without shielding

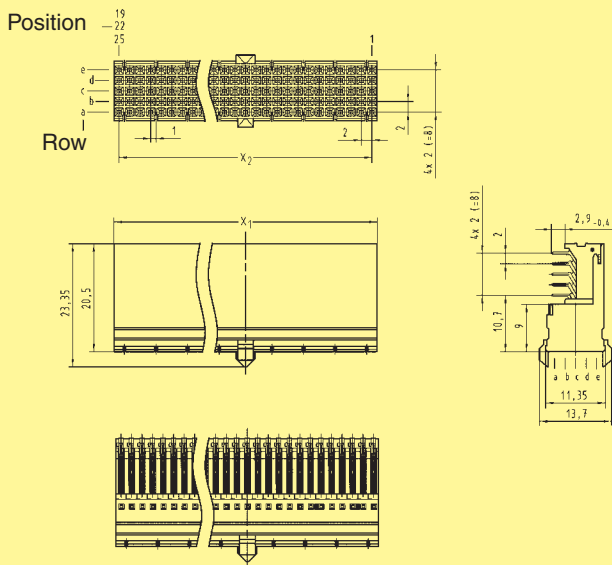

with shielding

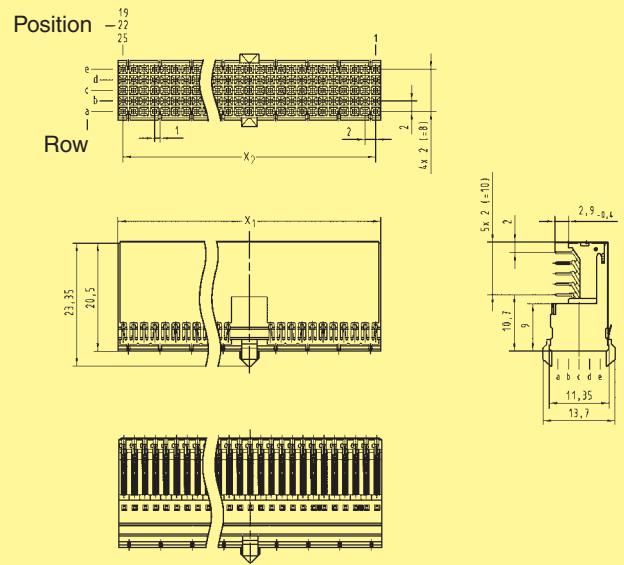

Board drillings

Diameter of drillings: $\varnothing 0.7 \pm 0.025$ mm
 Diameter of plated through holes: $\varnothing 0.6 \pm 0.050$ mm

Contact positions	X ₁	X ₂
19	38	18 x 2 (= 36)
22	44	21 x 2 (= 42)
25	50	24 x 2 (= 48)

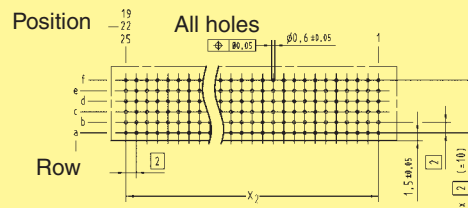
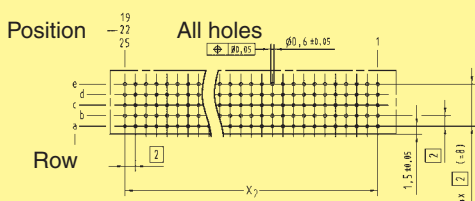

Dimensions [mm]

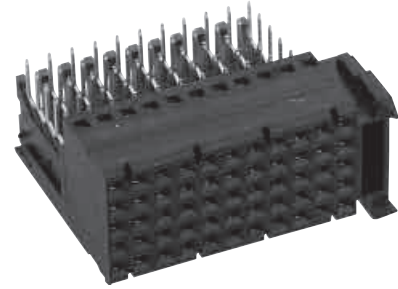

Female connectors, angled

Identification	No. of contacts	Contact length [mm] termination side	Part number
Type C	55	2.5	17 23 055 1801
Type C with upper shield	55	2.5	17 23 055 1802

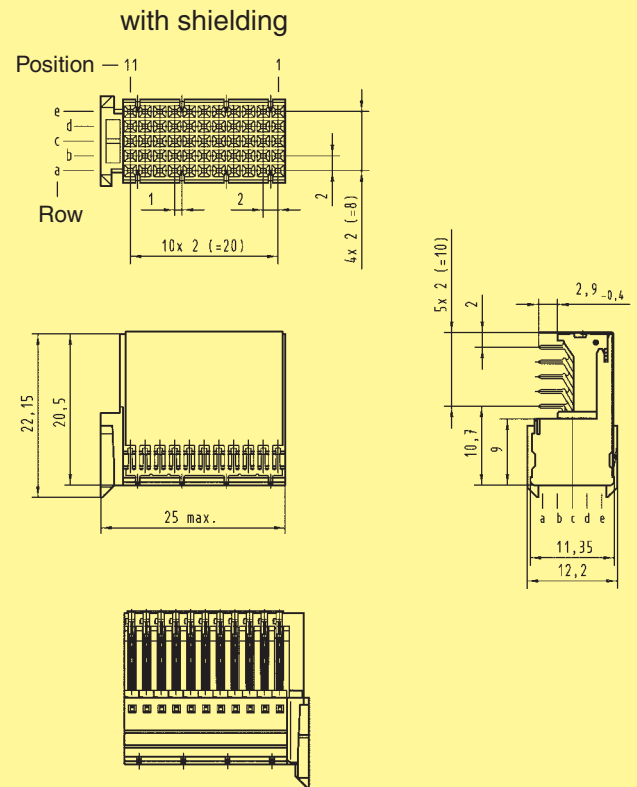
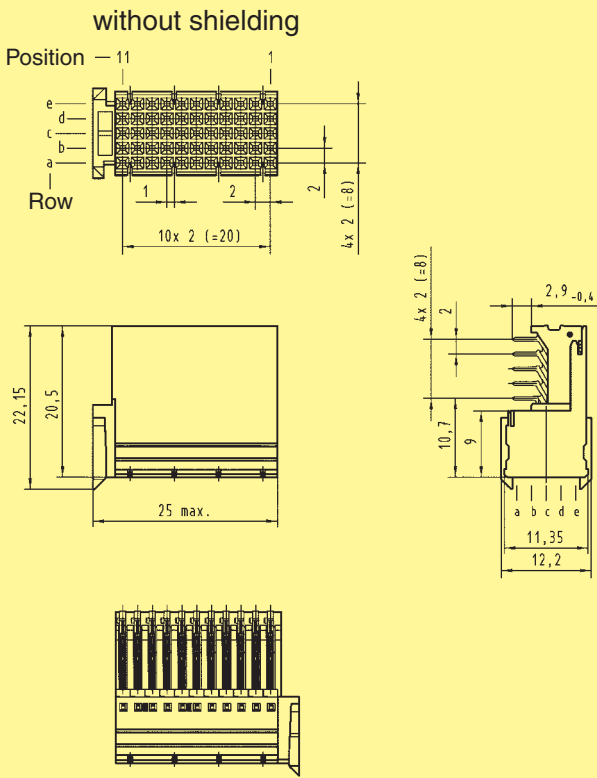

Board drillings

Diameter of drillings: $\varnothing 0.7 \pm 0.025$ mm
 Diameter of plated through holes: $\varnothing 0.6 \pm 0.050$ mm

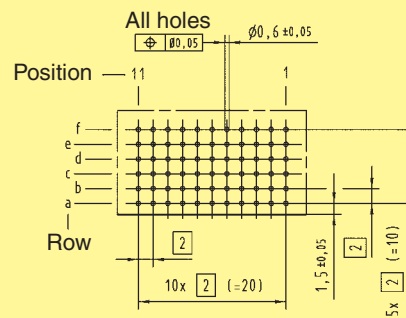
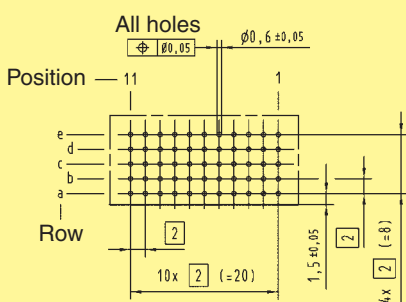

Dimensions [mm]