

Tooling

Page

Press-in technology

Modular tooling system for starting connector press-in	30.02
Handling indications	30.03
Press-in tooling	30.05
Repair tooling	30.07
Hand bench presses / pneumatic presses	30.11
CPM press-in machines	30.12
Press-in insert blocks and insertion removal station	30.14

Crimp technology

Manual crimping tools	30.16
Insertion and removal tools	30.16
Semiautomatic crimping tools	30.17
Automatic crimping tools	30.18

The diversity of connector types with press-in terminations and varying termination styles make it necessary to have a simple, flexible tooling system that can be continuously updated.

The HARTING modular tooling system has significant advantages in terms of economic assembly of the many connector types with press-in terminations. The basic modules of the tooling system which will always be required are:

- Press
- Top tool
- Bottom tool
- Base plate

To increase automation and productivity the following modules may be added to the basic assembly:

- Guide frame with base plate for accurate positioning of the pcb up to a length of 600 mm
- Guide frame "Standard" for hand bench press and pneumatic press and pcb height of 123.5 up to 309.5 mm
- Guide frame "Long" for pneumatic press and pcb height of 123.5 up to 668.5 mm

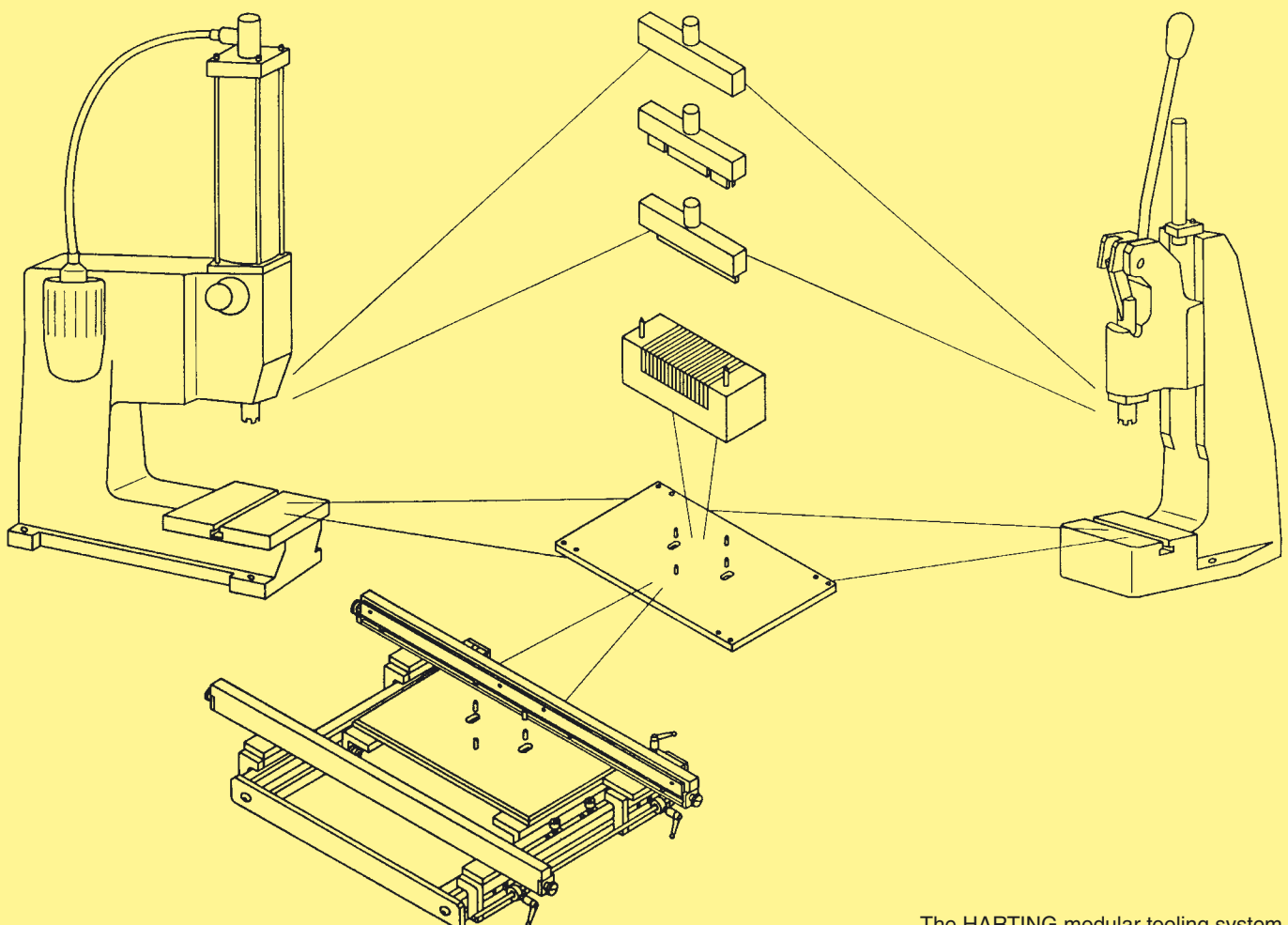

When setting up an assembly machine it is not necessary to set the working height of the press and adjust the base plate more than once. There is no need for further adjustments. All the other adaptations for various applications are performed efficiently and are reliant by various combinations of individual modules.

Positioning the bottom tool in relation to the top tool

The ram of the HARTING press is generally provided with a cross-shaped groove which accurately positions the top tool in steps of 90°.

Two guide pins position the bottom tool in relation to the top tool simply and accurately.

These guide pins cannot be used for positioning the pcb or the connector!

Two pairs of pins on the base plate locate the bottom tool in relation to the top tool in steps of 90°.

Height compensation

- Various overall heights of connectors are accommodated by type-specific top tools.
- Various pcb thicknesses are accommodated by the use of spacers between the bottom tool and base plate.

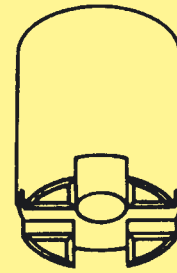

Ram with cross-shaped groove

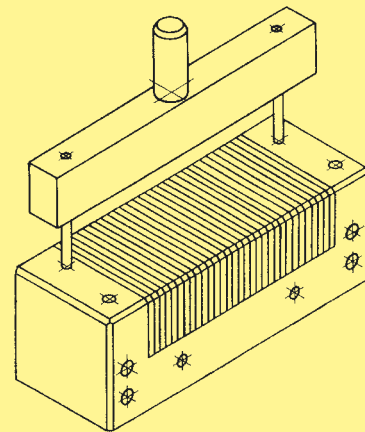

Positioning the bottom tool in relation to top tool

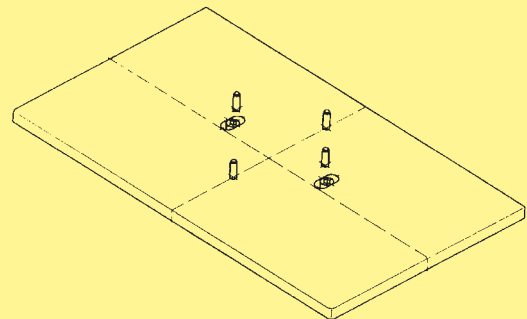

Base plate with pairs of location pins at 90°

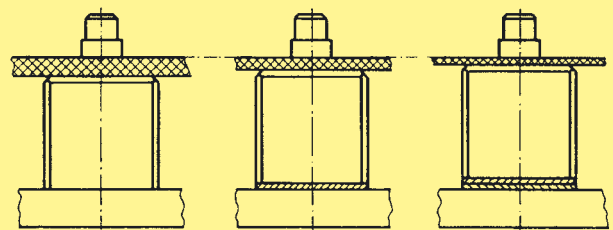
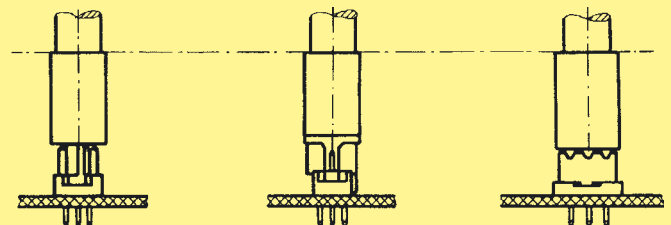

Range of applications for the bottom tool

One bottom tool can be used to assemble connectors with straight or angled press-in terminations.

When pressing in the connectors with angled press-in terminations the positioning pins remain in the bottom tool and serve as guide pins for the connector.

By rotating the bottom tool in steps of 90° and relocating the positioning pins it is possible to assemble half-length connectors with angled press-in terminations.

Bottom tool (narrow version)

In addition to the square bottom tool with multi-functional properties, HARTING offers the alternative of a narrow bottom tool for assembling connectors with straight press-in terminations. This tool supports the pcb within the press-in connector zone and therefore makes it possible to assemble connectors where electronic components are to be placed in close proximity.

Guide frame

The guide frame screwed to the base plate ensures the correct positioning of the pcb in relation to the top and bottom tools and permits a much higher rate of assembly.

Both guide rails are adjustable to accommodate various pcb sizes.

A spring-loaded supporting rail lifts the pcb away from the bottom tool after the press-in operation ensuring that no damage occurs to the conductors as it passes through the machine.

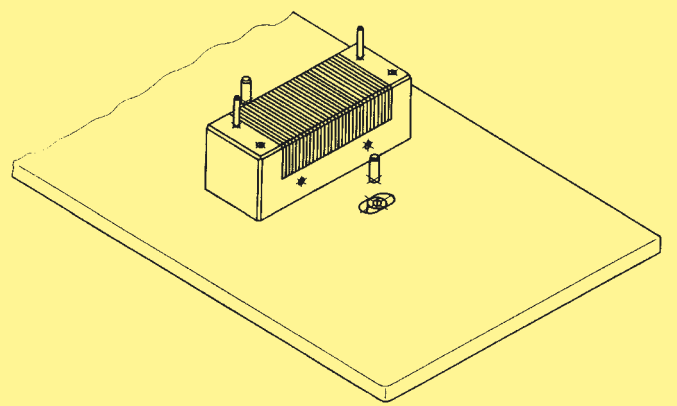

Bottom tool set for assembling connectors with angled pins

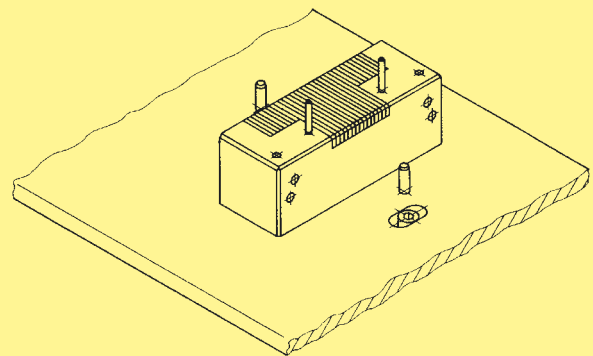

Bottom tool set for assembling half-length connectors with angled pins

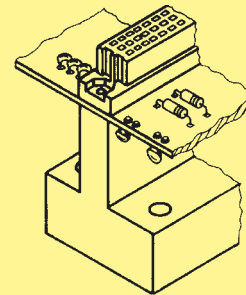

Narrow version of the bottom tool for special applications

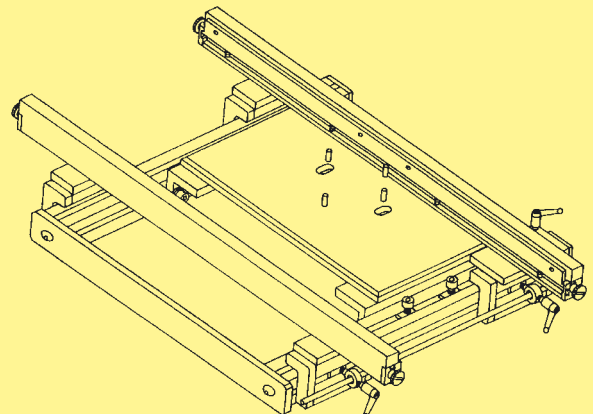

Guide frame for positioning the pcb in relation to the top and bottom tools

Identification	for use with	Part No.	Drawing
<p>Bottom tool Universal</p>	<p>Male and female connectors</p> <p>Type B, 2B C, 2C M Q, 2Q R, 2R E F har-bus® 64 har-bus® 64 inverse SEK 18*</p>	<p>09 99 000 0185</p>	
<p>Bottom tool Narrow</p>	<p>Male connectors</p> <p>Type Q, 2Q R, 2R SEK 18*</p> <p>Female connectors</p> <p>Type B, 2B C, 2C M F</p>	<p>09 99 000 0256</p> <p>09 99 000 0256</p>	
<p>Bottom tool Narrow</p>	<p>Female connectors</p> <p>har-bus® 64</p> <p>Male connectors</p> <p>har-bus® 64 inverse</p>	<p>02 99 000 0001</p>	

* Connectors see separate catalogue

Identification	for use with	Part No.	Drawing	Dimensions in mm
Top tool without insert block	Male connectors			Type Q, 2Q R, 2R
	Type Q, 2Q R, 2R	09 99 000 0181 09 99 000 0183		
with insert block	har-bus® 64 inverse	02 99 000 0012		Type Q, 2Q R, 2R har-bus® 64 inverse
	Type Q, 2Q R, 2R	09 99 000 0197		
with insert block	har-bus® 64 inverse	02 99 000 0002		Type Q, 2Q R, 2R har-bus® 64 inverse
	Type Q, 2Q R, 2R	09 99 000 0197		
Insert blocks	Male connectors			
Type Q 2Q R 2R	09 99 000 0275 09 99 000 0274 09 99 000 0277 09 99 000 0276			
	har-bus® 64 inverse	02 99 000 0011		
	har-bus® 64 shroud	02 09 000 0012		
Top tool	Female connectors			Type B, 2B C, 2C D-Sub* SEK 18* har-mik*
	Type B, 2B C, 2C	09 99 000 0197		
	E F	09 99 000 0221		Type E, F har-bus® 64
	har-bus® 64	02 99 000 0002		
	Type M (24+8) M (42+6) M (60+4) M (78+2)	09 99 000 0269 09 99 000 0270 09 99 000 0271 09 99 000 0272		
Top tool only for short posts and pcb thickness > 1.6 mm and without guide frame	Female connectors			Type B, 2B C, 2C
	Type B, 2B C, 2C	09 99 000 0228		
	F	09 99 000 0229		Type F

* Connectors see separate catalogues

Identification	for use with	Part No.	Drawing	Dimensions in mm															
Removal tool for moulding	Male connectors Type Q 2Q R 2R	09 99 000 0198																	
Removal tool for single male contacts		09 99 000 0239																	
Insertion tool for single male press-in contacts		09 99 000 0200																	
Press-out tool	Termination length 17 mm 13 - 13.2 mm 11.5 mm 4.5 - 5.3 mm	09 99 000 0197 09 99 000 0219 09 99 000 0221 09 99 000 0220		<table border="1"> <thead> <tr> <th>Termination length [mm]</th> <th>x [mm]</th> <th>y [mm]</th> </tr> </thead> <tbody> <tr> <td>17</td> <td>12</td> <td>18.7</td> </tr> <tr> <td>13 - 13.2</td> <td>12</td> <td>22.7</td> </tr> <tr> <td>11.5</td> <td>14</td> <td>20.1</td> </tr> <tr> <td>4.5 - 5.3</td> <td>12</td> <td>30.2</td> </tr> </tbody> </table> <p>With the different dimension y no adjustment of hand bench press necessary.</p>	Termination length [mm]	x [mm]	y [mm]	17	12	18.7	13 - 13.2	12	22.7	11.5	14	20.1	4.5 - 5.3	12	30.2
Termination length [mm]	x [mm]	y [mm]																	
17	12	18.7																	
13 - 13.2	12	22.7																	
11.5	14	20.1																	
4.5 - 5.3	12	30.2																	
Termination support for protection against bending of 13 mm - 17 mm terminations	Male connectors Type Q, 2Q R, 2R Female connectors Type B, 2B C, 2C	09 99 000 0240																	
	Female connectors Type F	09 99 000 0241																	
Support block	Male connectors Type Q, 2Q R, 2R SEK 18* Female connectors Type B, 2B C, 2C F	09 99 000 0218																	

* Connectors see separate catalogue

Replacement of single male press-in contacts

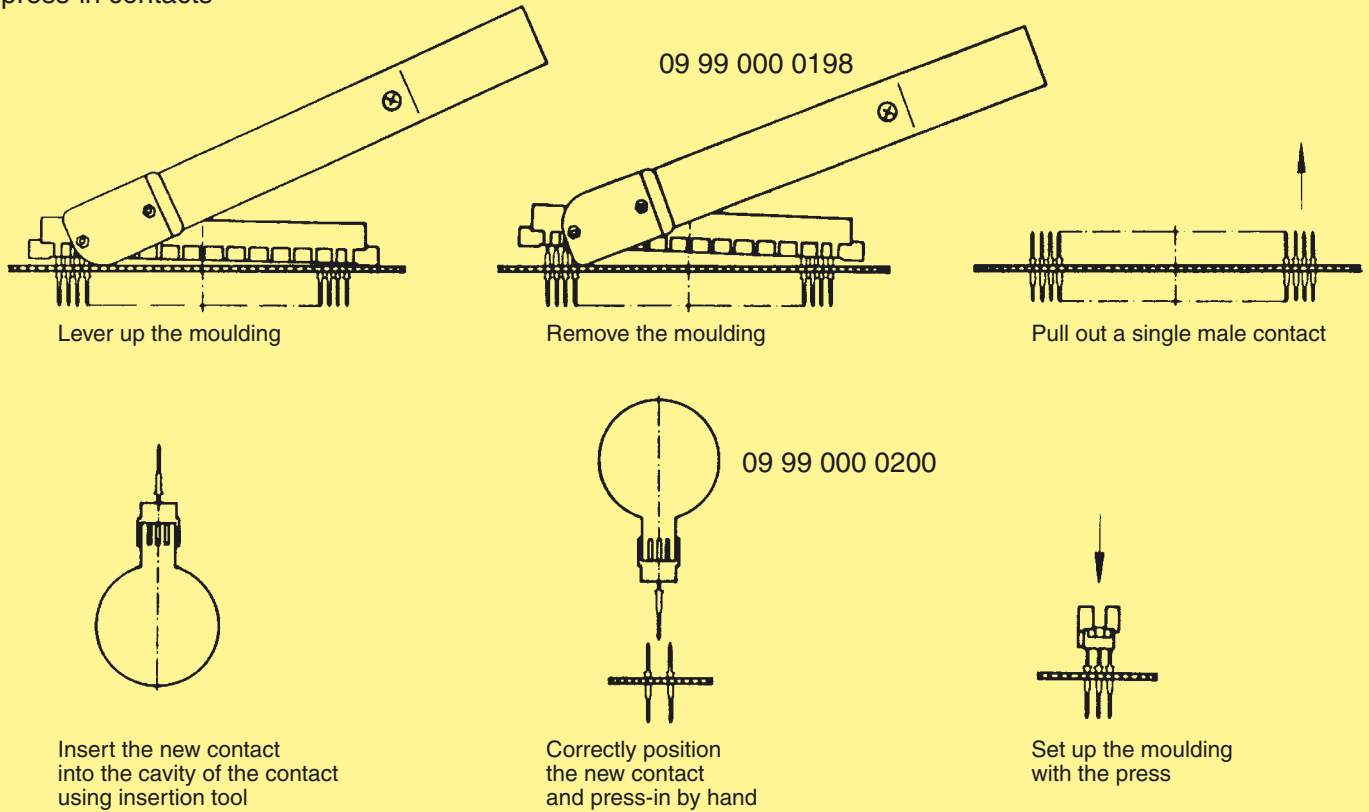

Replacement of complete press-in connectors

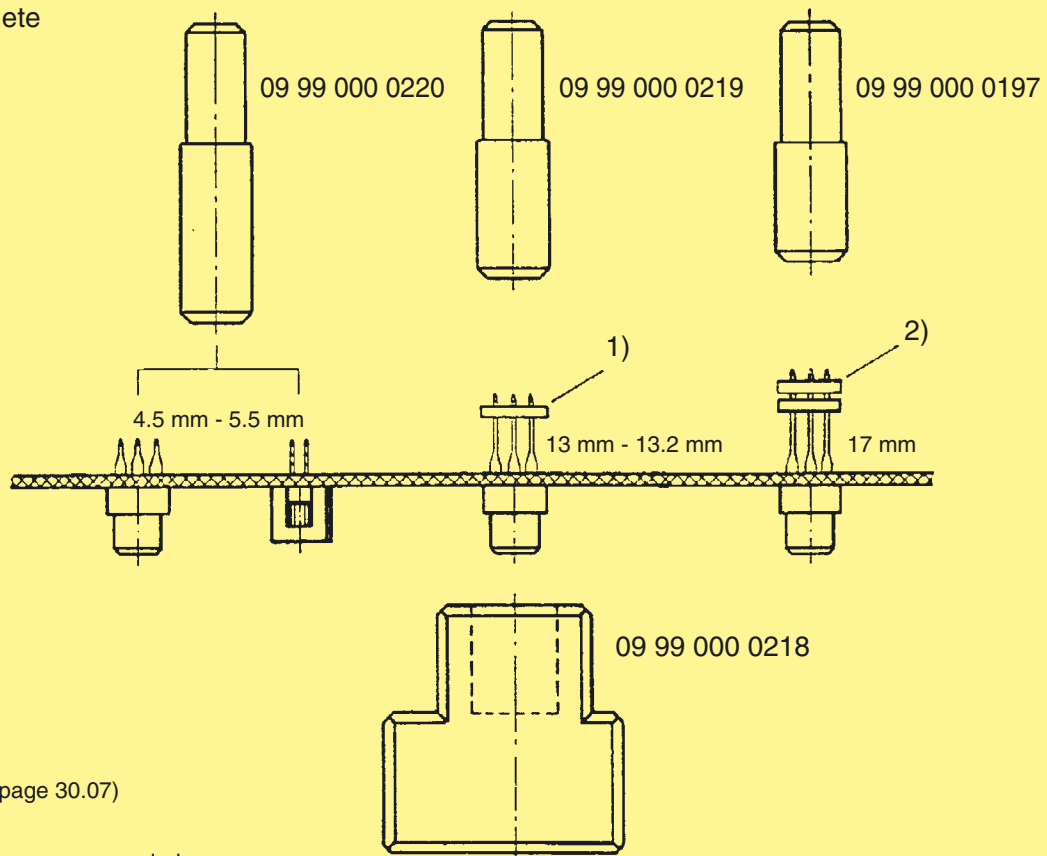

¹⁾ Termination support (see page 30.07)

²⁾ for 17 mm wrap posts
two termination supports are recommended

Identification	for use with	Part No.	Drawing	Dimensions in mm
Removal tool for moulding	Female connectors har-bus® 64	02 99 000 0003		
Removal tool (heavy duty) for moulding	Female connectors har-bus® 64	02 99 000 0006		
Press-out tool for 17 mm terminations	Female connectors har-bus® 64	02 99 000 0004		
Press-out tool for 5 mm / 4.5 mm terminations	Female connectors har-bus® 64	02 99 000 0008		
Support block	Female connectors har-bus® 64	02 99 000 0005		

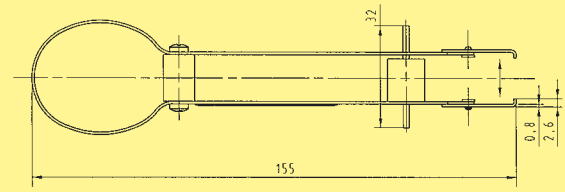
Identification	for use with	Part No.	Drawing	Dimensions in mm
Removal tool for shroud	rear I/O shroud har-bus® 64	02 99 000 0007		

Replacement of complete press-in connectors

Steps in detail

1. Lever up the moulding by using a removal tool

- a) The removal tool with Part No. 02 99 000 0003 is suitable for repairing small quantities. It can only be used if the adjacent components on the pcb are at least 2 mm apart from the moulding of the connector.
- b) The removal tool with Part No. 02 99 000 0006 is suitable for repairing large quantities. Due to its design it can also be used if components on the pcb are in close proximity to the moulding of the connector.

2. Lever up the rear I/O shroud with the removal tool 02 99 000 0007. This step is only required with 17 mm termination length.

3. Pull out the female contacts with the press-out tool

- a) for 17 mm termination length use Part No. 02 99 000 0004 and
- b) for 5 mm termination length use Part No. 02 99 000 0008.

During this process the press-out tool replaces the top tool and the pcb is supported by the support block (Part No. 02 99 000 0005) from the bottom.

Identification	Part No.	Drawing	Dimensions in mm
Hand bench press	09 99 000 0201		<p>Technical characteristics</p> <p>Working stroke 25 mm</p> <p>Press force 15 kN max.</p> <p>Hole ϕ in the ram ϕ 10 mm</p> <p>Net weight approx. 23 kg</p>
Pneumatic press 40 kN	09 99 000 0281		<p>Technical characteristics</p> <p>Total stroke 48 mm</p> <p>Working stroke 0-6 mm</p> <p>Press force 40 kN max.</p> <p>Air pressure 6 bar</p> <p>Hole ϕ in the ram ϕ 10 mm</p> <p>Net weight approx. 320 kg</p>
Adaptor for height compensation ¹⁾	09 99 000 0279		
Guide frame with base plate Standard type for pcb size x = 123,5 - 309,5 mm	09 99 000 0244		
Long type for pcb size x = 123,5 - 668,5 mm	09 99 000 0261 ²⁾		
Base plate	09 99 000 0255		

¹⁾ suitable for 09 99 000 0281 and all CPM machines (see page 30.12 pp.)

²⁾ not suitable for hand bench press

CPM 2001/s - press-in machine with a graphical user interface

The CPM 2001/s is the latest state of the art press-in machine. Optimised for pressing-in components into both daughter cards and backplanes, the machine is fully programmable and offers greater flexibility with a shorter set up time.

Different component heights can be stored and recalled later by simply using the “go/press” button. A TFT flat screen with Windows™ based software continuously displays all relevant information to the operator (connector position on the pcb, press-in forces etc.), thus consequently eliminating errors. A barcode reader recognises all pcb data and corresponding process programmes. Companies with multiple manufacturing sites can continuously equip and update machines with the latest programmes developed by specialists at their headquarters. The reliable and unique press-in method „autosense“ offers outstanding security for processes, as pcb tolerances and connector types are recognised and taken into consideration automatically.

CPM 2001/s



Part No. 09 89 030 0000

Technical characteristics

Drive	electromechanical
Press-in force	100 kN
max. pcb dimensions	600 x 1000 mm
Floor space	1200 x 960 mm
Height	2150 mm
Weight	950 kg
Power supply	380 / 400 / 415 V 3 phases, 16 A
Consumption	< 1 kW
Colour	RAL 7038

CPM 2001/s incl. PC, control software, barcode reader, keyboard, touch screen

Equipment:

- PC incl. Win95™ with control software to store and manage all programs and process data
- Barcode scanner for management ease of press-in programs
- Touch screen for a direct user interface

Process control:

- Continuous recording of press-in force and press-in distance data
- Press-in method “autosense”
- Automated recording and imaging of all process data, as well as process interruption at non compliant force values
- User guidance through pictures
- Clear assignment of pcb and process data

Options:

- Rotatable tool changer
- Insertion removal station

The **CPM prestige** press-in machine with a graphical user interface

The **CPM prestige** is a consequential development of the successful CPM 2001 press-in machines. The excellent design, supported by a wide range of tools presents a convenient, easy and comfortable way of populating backplanes and daughtercards. The machine is fully programmable and is supplied with a graphical user interface for control and visualisation of the complete process.

The use of a microprocessor control allows the recognition and storage of different component heights, so that the pressing-in of different components is initiated simultaneously with only one button.

The user-friendly touch-screen guides the user through the menu-orientated process controls. The visualisation of the entire press-in process (the position of the connector, press-in forces etc.) allows the rapid recognition and eradication of the possible error sources. With the addition of a barcode reader (1D and 2D) the parameters of every pcb layout can be stored, recalled and loaded into the automated press-in programme. The extensive operation monitor functions simplify the service and support of the machine.

The machine employs the automatic switch-off system "autosense", known worldwide for its reliability. The different connector types and the tolerances of the pcb are automatically recognised and taken into consideration at the press-in operation, thus maximising the process security.

CPM prestige



Part No. 09 89 040 0000

Technical characteristics

Drive	electro-mechanical, servo
Press-in force	100 kN
max. pcb dimensions	600 x 1000 mm
Floor space	1200 x 1150 mm
Weight	980 kg
Power supply	208 / 380 / 400 / 415 V
Consumption	< 1 kW
Colour	on request

CPM prestige

(incl. PC, control software, barcode reader, keyboard, touch screen)

Features:

- Guiding rails for the secure positioning of the pcb
- Touch-screen and Industrial PC with UPS (uninterruptable power supply)
- Barcode reader for management ease of press-in programs
- All dimensions allow an easy integration into production lines

Process monitoring and quality assurance:

- Touch screen interface with graphical and verbal menus for all machine functions
- Autosense: automated press-in interruption at incorrect press-in forces
- Storage and validation of all press-in parameters via quality assurance software (press-in force tolerances)
- Continuous high-precision measurement and recording of press-in forces and distances
- Remote determination of errors and maintenance
- High flexibility through a modular tool range

Options:

- Rotatable tool changer
- Insertion removal station

Today nearly all female connectors are designed for flat rock tooling. For every type of male connector specific tooling and a high degree of X-Y-process accuracy is required. Therefore HARTING offers press-in insert blocks that transfer all well known assembling advantages from female connectors to male headers.

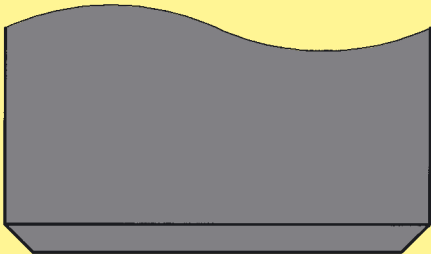

Advantages of press inserts

Robust tooling

No lateral force to pcb hole

No abrasion of the contact mating surface by the press tool

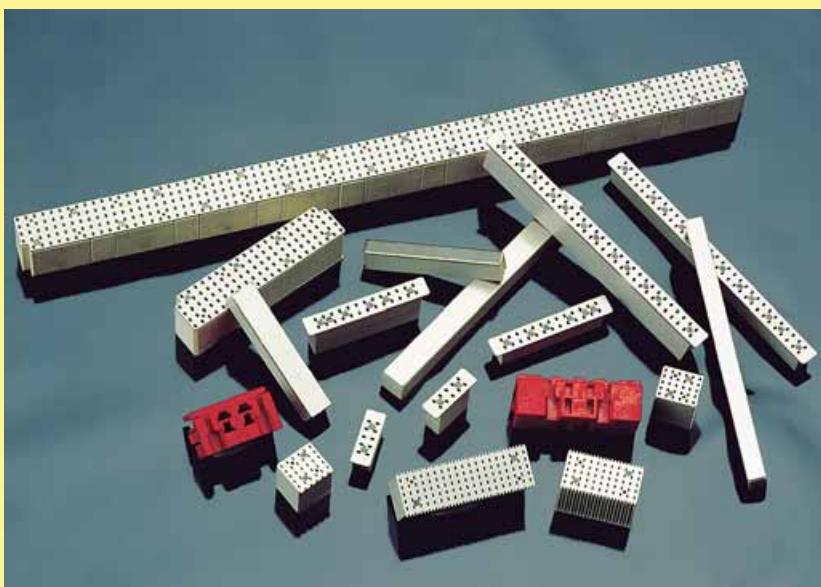
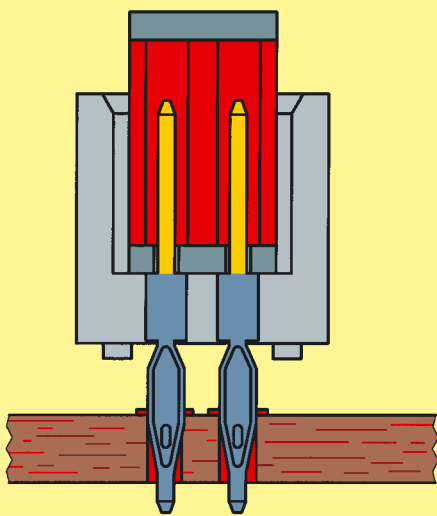

HARTING has already developed press-in inserts for all major male connector families on 2.54 mm, 2.5 mm and 2 mm.

Inserts for any other special components can be developed on request.

The additional work step for inserting and removing the press-in inserts can be efficiently done with the insertion removal station. This station removes all press-in inserts with a magnetic plate in one operation and inserts them into the next pre-assembled pcb with the necessary precision. (Principle see page 30.15).

The cycle time for loading all headers is between 4 and 6 seconds, independent from the amount of press-in inserts.

To load the inserts automatically means also that connectors assembled in a wrong way will be recognised and errors consequently prevented.

Principle:

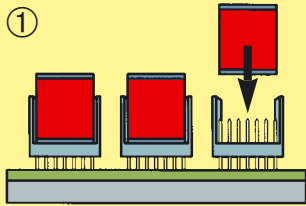

① Load all headers with inserts **for one press-in cycle**

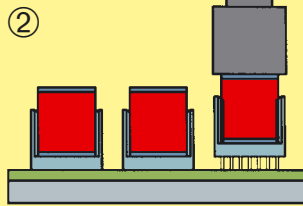

② Press-in all connectors with a flat die

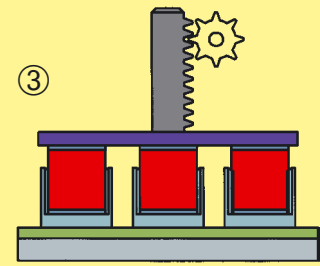

③ Position the magnetic plate

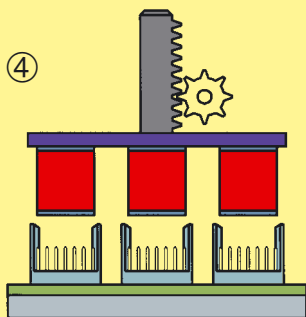

④ Remove all press-in inserts in one operation

Remove the processed pcb from the machine



⑤



⑥

Move the next pre-assembled pcb to the insert station

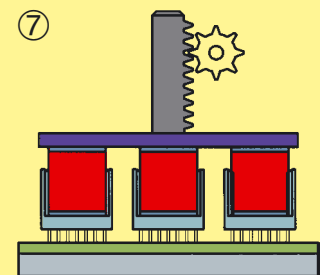

⑦ Load all headers in one operation

The insertion removal station has been developed both for the **CPM prestige** and the CPM 2001/s. It can additionally be used as stand alone equipment.

Insertion removal station



Power supply

220 V / 50 Hz

Air pressure

6 bar (15-16 l/min.)

Part No.

09 89 020 0070









for pcb dimensions
710 mm x 540 mm

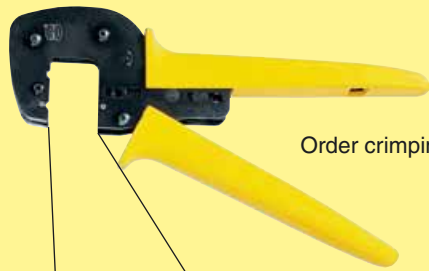
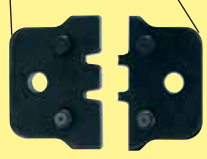

Part No.

09 89 020 0060

for pcb dimensions
1000 mm x 600 mm

Bestseller **CPM 2001/s** with insertion removal station, adaptable to all HARTING press-in machines.

Identification	Part No.	Drawing	Dimensions in mm	
HARTING crimping tool for individual contacts BC and FC	09 99 000 0620	 <p>Order crimping inserts separately</p>  <p>Wire gauge BC: 0.09 - 0.50 mm² FC 1: 0.09 - 0.25 mm² FC 2: 0.14 - 0.56 mm² FC 3: 0.50 - 1.50 mm²</p>  		
Crimping insert set for individual contacts each set contains locator and crimp insert top and bottom part				
BC / FC 1	09 99 000 0621			
FC 2	09 99 000 0622			
FC 3	09 99 000 0623			
Locator				
BC	09 99 000 0630			
FC	09 99 000 0631			
Service case for crimping tool and 5 sets inserts, incl. screwdriver for insert change, without contents	09 99 000 0632			
HARTING crimping tool for bandoliered contacts (500 pieces) BC	09 99 000 0248	 <p>Wire gauge 0.09 - 0.5 mm²</p> <p>Wire gauge 0.09 - 0.25 mm² 0.14 - 0.56 mm² 0.50 - 1.50 mm²</p>		
for bandoliered contacts (250 pieces)				
FC 1	09 99 000 0247			
FC 2	09 99 000 0119			
FC 3	09 99 000 0120			
Tooling	Crimping tool for individual contacts FC 1, FC 2 and FC 3 (Service tool)	09 99 000 0191	 <p>Wire gauge 0.14 - 1.5 mm²</p> <p>Locator is supplied with the tool.</p>	
	Insertion tool for contacts BC	09 99 000 0100		
	for contacts FC 1, FC 2 and FC 3	09 99 000 0088		
Removal tool for contacts BC	09 99 000 0101			
	for contacts FC 1, FC 2 and FC 3	09 99 000 0087		

Identification	Part No.	Drawing	Dimensions in mm
<p>HARTING semi-automatic crimping device</p> <p>Main drive, foot-operated 115/230 V – 50 Hz</p>	<p>09 99 000 0246</p>	 <p>Locator not necessary</p>	
<p>Crimping head for bandoliered contacts</p> <p>BC</p> <p>FC1</p> <p>FC2</p> <p>FC3</p>	<p>09 99 000 0252</p> <p>09 99 000 0249</p> <p>09 99 000 0250</p> <p>09 99 000 0251</p>	<p>Wire gauge</p> <p>0.09 - 0.25 mm²</p> <p>0.09 - 0.25 mm²</p> <p>0.14 - 0.56 mm²</p> <p>0.5 - 1.5 mm²</p> 	
<p>Real holder for 2,500 contacts FC1, FC2 or FC3 and for 5,000 contacts</p> <p>BC</p>	<p>09 99 000 0158</p>		

Automated crimping machine type BK

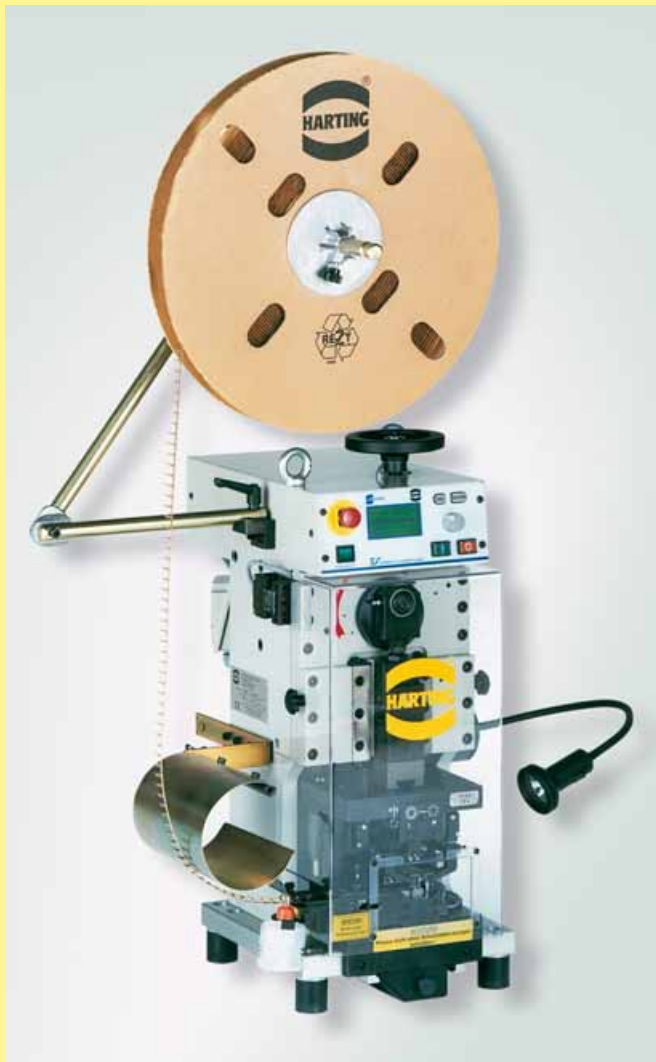

Main characteristics

- Smooth run through electronic brakes
- Hand wheel for manual adjustments
- Maintenance friendly through needle bearing rail
- Easy handling through straight forward design

Part No. 09 98 000 5000

Technical Characteristics

Dimensions

Height 690 mm
(1400 mm with a contact reel)

Width/Breite 350 mm

Depth/Tiefe 370 mm

Total weight 85 kg

Power supply 230 V, 50/60 Hz, 2.5 A

Consumption 0.75 kW

Motor speed 440 - 2000 rpm

Cable length 2 m incl. plug

Control SPS

Work cycle trigger Sensor

Work cycle 0.35 s for stripping and crimping

Illumination Unolux F 230 V /
50 Hz / 20 W

Stroke counter Daywise and fixed

Crimp force monitor BB07i (optional), part no.
09 98 336 6801

Crimping tool Pillar guided
Cam controlled

Adjustable process parameters Crimping height on wire
Crimping height on insulation
Depth of insulation stripping
Length of insulation stripping
Wire retainer position
Wire position in the crimp contact
Band thrust

Identification	for use with	Part No.	Wire gauge [mm ²]	AWG	Insulation [Ø mm]
Crimping tool for DIN 41 612 connectors ¹⁾	contacts BC	09 98 000 2004	0.09 - 0.56	28 - 20	0.7 - 1.6
	contacts FC1	09 98 000 2005	0.09 - 0.25	28 - 24	0.7 - 1.6
	FC2	09 98 000 2006	0.14 - 0.56	26 - 20	0.8 - 2.3
	FC3	09 98 000 2007	0.50 - 1.50	20 - 16	1.6 - 2.8
for D-Sub connectors ²⁾	standard contacts	09 98 000 2008	0.09 - 0.25	28 - 24	0.7 - 1.4
		09 98 000 2009	0.25 - 0.50	24 - 20	0.9 - 1.7
Crimping tools for further contacts on request					

Identification	conversion from	Part No.	
Extension modules for FC crimping tools for DIN 41 612 connectors ¹⁾	FC2 or FC3 to FC1	09 98 302 2621	
	FC1 or FC3 to FC2	09 98 302 2622	
	FC1 or FC2 to FC3	09 98 302 2623	
for D-Sub connectors ²⁾	AWG 28-24 to AWG 24-20	09 98 302 2629	
	AWG 24-20 to AWG 28-24	09 98 302 2628	

¹⁾ 3.5 + 0.5 mm of insulation is stripped from the wire to be crimped

²⁾ 2.5 + 0.5 mm of insulation is stripped from the wire to be crimped

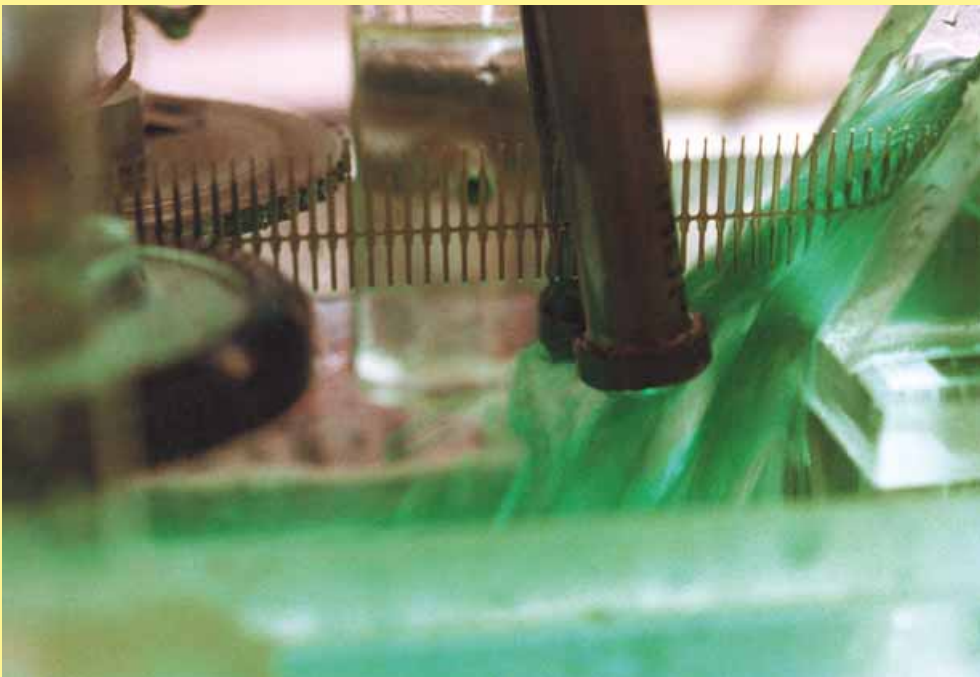

High quality contact surfaces require expertise and latest technological equipment.

Technology at HARTING preserves natural resources thus improving the environment