

HARTING

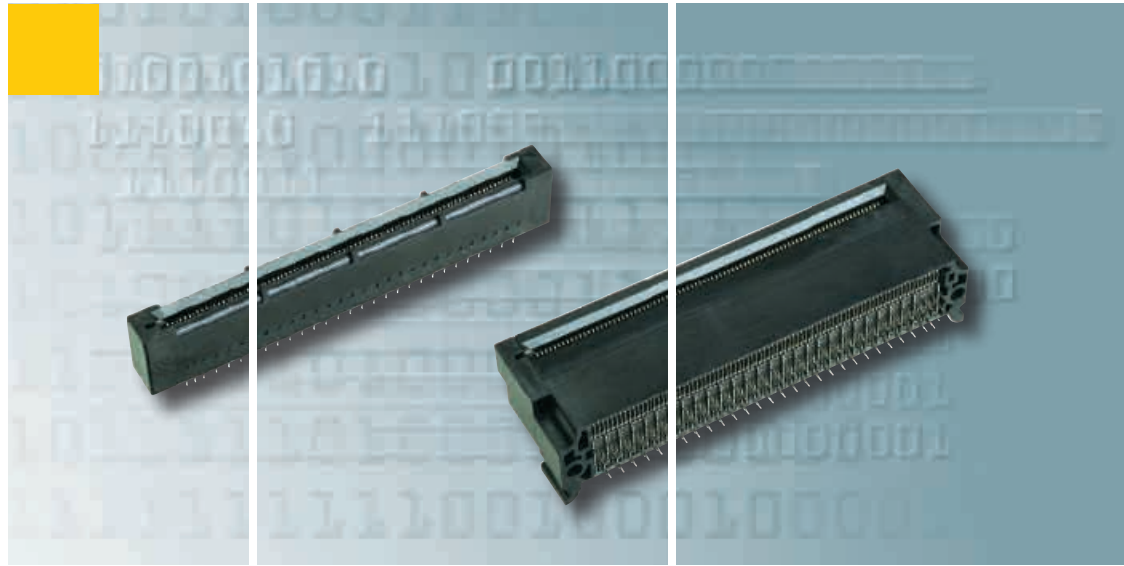

TCA Connectors

Quality Connections Worldwide

HARTING was founded in 1945 by the family that still owns the company.

Today, HARTING employs around 2,000 people worldwide, including 150 qualified engineers. The sales team, including more than 100 sales engineers is in daily contact with our customers.

The company is one of the world's leading manufacturers of connectors, and currently have 34 subsidiary companies in Europe, the United States and Asia. In several product areas, HARTING is a market leader.

Great emphasis is placed on close links with customers, including the provision of a 'Just-in-Time'-Service to ensure rapid delivery to key customers.

HARTING products are designed and manufactured using the latest automated techniques, from CAD systems in the research and development department to automatic production techniques on the assembly lines.

Production and quality control is based on a 'zero-error' philosophy which can only be reached by the continuous successful implementation of fully automated production techniques. The organisation and procedures for quality assurance are based on the EN ISO 9001 standard. A total of 60 engineers and other employees, most of whom are trained and qualified to standards laid down by the DGQ (German Association of Quality) or the SAQ (Swiss Association of Quality), are employed solely on quality-assurance activities.



TCA Connectors

Page

General information 4



..... 6

AdvancedMC™ connectors
for AdvancedTCA® 8



Power connectors
for AdvancedTCA® 10



AdvancedMC™ connector
for MicroTCA™ 12

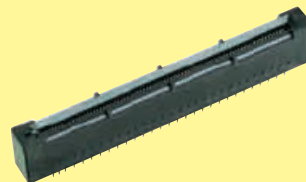

Power output connectors
for MicroTCA™ 14

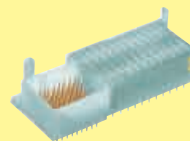

Press-in tooling 16

Signal integrity support 18

Company addresses 20



PICMG, formally known as the PCI Industrial Computing Manufacturing Group – is an industry consortium of over 450 companies. PICMG's purpose is to define standard architectures in an effort to reduce system costs and development

cycles and since its 1994 foundation, PICMG has been responsible for the establishment of several of successfully implemented, open, industrial standards. Open standards have proven themselves to be very advantageous for system manufacturers and end-user, because they create multiple vendors of similar parts, low prices at high volumes, and a shortened time-to-market.

Historically, PICMG has created several successful standards.

- PICMG 1.x Series – a passive backplane PCI specification
- PICMG 2.x Series – the CompactPCI® standard

AdvancedTCA®

Today, the AdvancedTCA® series of specifications (PICMG 3.x) targets the requirements of the next generation of carrier grade telecommunications equipment. AdvancedTCA®, short for Advanced Telecom Computing Architecture and sometimes simply abbreviated ATCA®, incorporates an impressive suite of recent technological advancements including the latest trends in high speed interconnect technologies.

Features of AdvancedTCA® include optimization for high-capacity, high-performance telecom and industrial applications, improved reliability, manageability, redundancy, and serviceability. Encompassing a technological growth path valid for up to ten years, AdvancedTCA® has earned a solid position within the telecom systems market.

The rack or chassis, is responsible for housing the backplane and the daughtercards, as well as cooling



AdvancedTCA® chassis with backplane

and powering the system. From on the second quarter of 2007, HARTING offers the ATCA® power connector that energises the blades, both the straight backplane and the right angled daughtercard connector.

The backplane, said to be passive, is merely a medium for the daughtercards to communicate with each other. And, the daughtercards, sometimes called blades or boards, provide the system with its functionality and allow for an easy, hot-swappable module exchange from the front of the system.

Initially, many blades were designed with a fixed functionality, and they had to be replaced once their functionality became obsolete or the demands of the system changed. With the continuation of exponential technological growth, concept proved to be a costly endeavour for the end-user.

AdvancedMC™

To extend the functionality and modularity of AdvancedTCA®, blade manufacturers conceived the idea of upgradeable daughtercards, and began to insert mezzanine cards onto the blades when needed. To achieve a common mezzanine concept, PICMG developed the Advanced Mezzanine Card (AdvancedMC™) standard AMC.0.

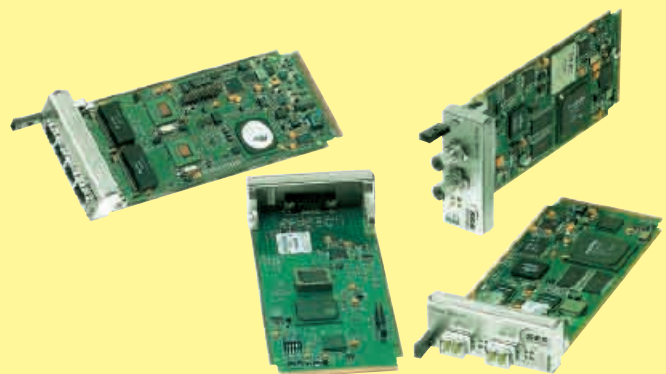

AdvancedMC™ modules for different applications

For the use of Advanced Mezzanine Cards, as well called AdvancedMC™ modules, a carrier is necessary. A carrier is an ATCA® blade with only little functionality beyond AdvancedMC™ management. It contains the mechanical environment for the AdvancedMC™ modules. Depending on their size, up to eight AdvancedMC™ modules can be hot-swapped in and out of a carrier, this enabled the creation of extremely scalable and upgradeable systems.



AdvancedTCA[®] carrier board with AdvancedMC[™] modules

To connect AdvancedMC[™] modules to carrier boards PICMG defined a new high-speed mezzanine connector: the AdvancedMC[™] connector – a card edge connector mounted on the carrier board. It contacts directly with the module's pcb gold pads. Although PICMG defined four AdvancedMC[™] connector types (B, B+, AB and A+B+), current market developments focus on type B+.

The HARTING AdvancedMC[™] B+ connector features a new design element that supplements the standard – the GuideSpring. The GuideSpring significantly increases the mating reliability and prevents contact interruptions and surface wear when subjected to shocks or vibrations.

The press-fit termination technology provides significant cost and durability advantages over other termination technologies. The connector design allows for the use of a standard flat rock die. For more press-in process control, HARTING offers a special top and bottom tool (see page 16).

The AdvancedMC[™] standard covers a wide range of applications:

- AMC.1 PCI Express and advanced switching
- AMC.2 Gigabit Ethernet / 10 Gigabit XAUI Ethernet
- AMC.3 Storage
- AMC.4 Serial RapidIO

μTCA[™]

This revolutionary AdvancedMC[™]-based design concept has led to the recent development of a completely mezzanine-based system – MicroTCA[™]. MicroTCA[™], short for Micro Telecom Computing Architecture, is a more cost-efficient platform than AdvancedTCA[®] when dealing with smaller applications, yet powerful enough to address the needs of telecom, enterprise and medical applications.

This newly-implemented PICMG standard, outlined in the MTCA.0 specification, presents a design-concept whereby AdvancedMC[™]s – the same kind used in ATCA[®] systems – plug directly into a passive backplane; this eliminates the need for carrier boards.



MicroTCA[™] double cube system

Naturally the mating face of the AdvancedMC[™] connector for MicroTCA[™] is the same as for ATCA[®], but with a right angled mating direction. It contains the new GuideSpring and is available in press-in termination. PICMG members voted HARTING's MicroTCA[™] connector footprint as the new MicroTCA[™] standard connector for press-fit termination technology.

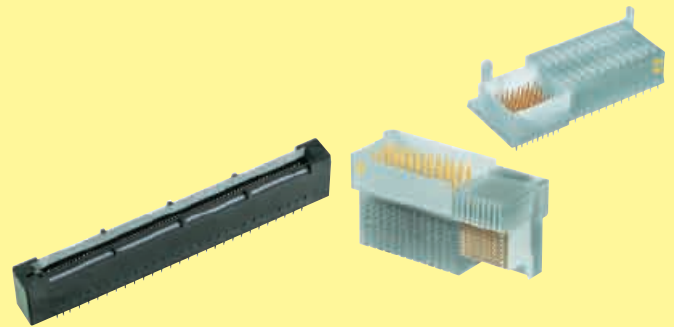

AdvancedMC[™] and power connectors for MicroTCA[™]

The MicroTCA[™] backplane is typically powered by special, field replaceable, hot-swappable, redundant Power Supply Units (PSU). The PSU connects to the backplane through a MicroTCA[™] power connector (press-fit termination) also available from HARTING.

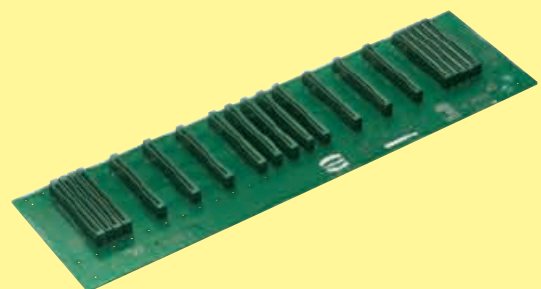

MicroTCA[™] backplane

The module management is performed by a MicroTCA[™] Carrier Hub, or MCH. An MCH is connected to the backplane by up to four adjacent card-edge connectors. One MCH can control up to 12 AdvancedMC[™] modules, thus depending on redundancy requirements, workload, or both, one or two MCHs may be used within a single system.

What is **con:card+**?

con:card+ is a quality seal for AdvancedMC™ connectors that helps to deliver a significant increase in the reliability of MicroTCA™ and AdvancedTCA® systems. In order to reach the target availability of 99.999 %, all system components must be carefully coordinated, and they must function reliably. The selection of suitable

connectors is an essential, decisive factor here, as today it is virtually impossible for series production to meet the strict tolerances for the AdvancedMC™ modules as defined in the respective specifications. The so-called GuideSpring is ideally suited for compensating here, and represents just one of a total of five key advantages of the **con:card+** philosophy. All the advantages are introduced in the following.



Special contact material

Unlike conventional mating systems with male and female connectors, the AdvancedMC™ has only one, not two, contact tongues per contact. In order to ensure a permanently reliable contact, this single contact tongue must press against the gold pad with sufficient force throughout the entire lifetime. In addition, the thickness of the AdvancedMC™ modules may fluctuate by $\pm 10\%$. To meet this challenge, HARTING utilizes a special alloy with very low relaxation as the contact material for the **con:card+** connector.



PdNi contact coating

In order better to meet the high requirements placed on the connectors, a palladium-nickel surface (PdNi) with additional gold flash is used. As a result, wear resistance is increased by roughly 30 %. Even when applied very thinly, PdNi surfaces offer a quality and corrosion-resistant coating that meets the high requirements placed on the connection far better than pure gold.





Smooth contact surface

The specification for the AdvancedMC™ entails 200 mating cycles for a module. On the pcb, the nickel/hard gold layer on the relatively soft copper can only stand up to this high load if the contact surface is absolutely smooth.

This is the case with the **con:card+** connector. With years of experience in stamping techniques and the utilization of high-performance stamping tools with special process components, HARTING is actively involved in minimizing gold pad wear.



GuideSpring

Pcb manufacturers are not capable of meeting the AdvancedMC™ modules' tight tolerances with certainty in the series process today. Just a single card with tolerances slightly larger than allowed by the specifications can lead to a system breakdown.

The **con:card+** GuideSpring offsets these tolerance deviations by constantly pressing the module against the opposite wall. As this is displaced somewhat towards the middle, the slot is optimally designed for the AdvancedMC™ module, and the mating reliability increases tremendously.

In addition, the GuideSpring secures the module position in the case of shocks and vibrations. This prevents loss of contact and surface wear.

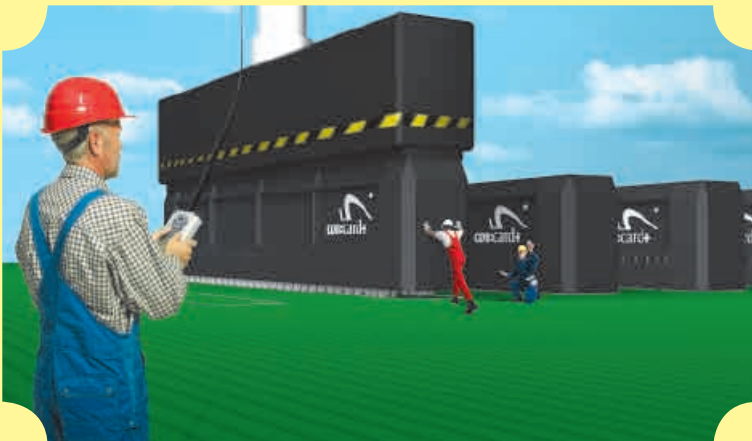

Press-fit technology

Press-fit technology results in a gas-tight, corrosion-resistant, low-ohm quality mechanical connection between the pin and the through contacting of the pcb. This remains reliably in contact and stable, even under conditions of high mechanical and thermal loads, such as vibration, bending and frequent temperature changes. This technology represents a tremendous advantage over other processing techniques. Measurements substantiate that the required transmission rates are easily attained.

Technical characteristics

Design according PICMG AMC.0
(RoHS compliance)

Number of contacts 170
Contact spacing 0.75 mm
Clearance and creepage distance between contacts 0.1 mm min.

Working current of power contacts as defined in AMC.0 spec. 1.52 A @ 70 °C
max. 30 °C temp. rise
Test voltage 80 V_{r.m.s.}
Contact resistance ground contacts 60 mΩ max.
signal, power, general purpose contacts 90 mΩ max.
Insulation resistance 10 MΩ

Nominal differential impedance 100 Ω ± 10 %
Near end crosstalk (pair-to-pair) @ 30 ps risetime

basic-to-basic	< 0.6 %
basic-to-extended	< 0.9 %
extended-to-extended	< 0.6 %
diagonal	< 0.3 %
multiline	< 3.0 %

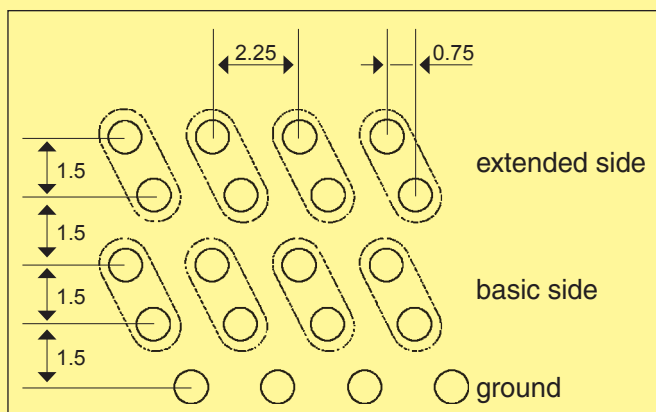

Differential propagation delay
Basic side: 125 ps
Extended side: 145 ps
Differential skew
Between basic and extended side: 20 ps
Within basic and extended side: ± 2 ps

Temperature range -55 °C ... +105 °C
Durability as per AMC.0 specification 200 mating cycles

Termination technique Press-in termination
Mating force 100 N max.
Withdrawal force 65 N max.

Materials

Moulded parts Liquid Crystal Polymer (LCP), UL 94-V0
Contacts Copper Alloy
Contact surface Palladium nickel plated

Packaging Card box (other packaging on request)

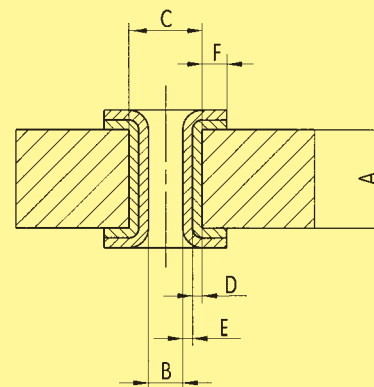

Plated through hole recommendations		
A	pcb thickness	min. 1.4 mm
B	Plated hole-Ø	0.55 ± 0.05 mm
C	Hole-Ø	0.64 ± 0.01 mm
D	Cu	min. 25 µm
E	Plating	- min. 0.8 µm chem. Sn - 0.05 - 0.12 µm Au over 3 - 7 µm Ni - 0.1 - 0.3 µm Ag
F	Pad width	min. 0.15 mm



Card edge connectors, angled

Identification	No. of contacts	Contact length [mm] termination side	Part number
AdvancedMC™ connector for ATCA®, type B+ with peg and with GuideSpring	170	2.0	16 04 170 5104 000
AdvancedMC™ connector for ATCA®, type B+ without peg and with GuideSpring	170	2.0	16 04 170 5106 000

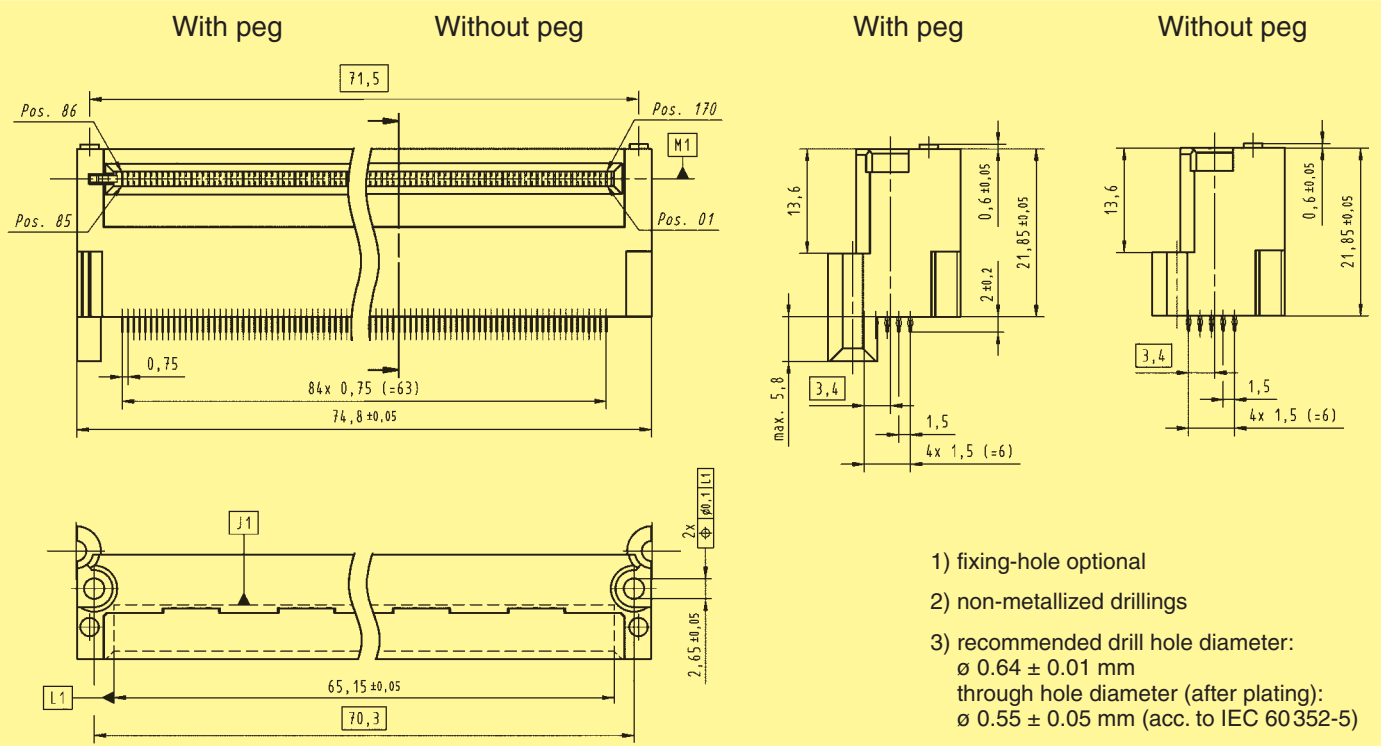

- 1) fixing-hole optional
- 2) non-metallized drillings
- 3) recommended drill hole diameter:
 $\varnothing 0.64 \pm 0.01$ mm
 through hole diameter (after plating):
 $\varnothing 0.55 \pm 0.05$ mm (acc. to IEC 60352-5)

Board drillings (view magnified)

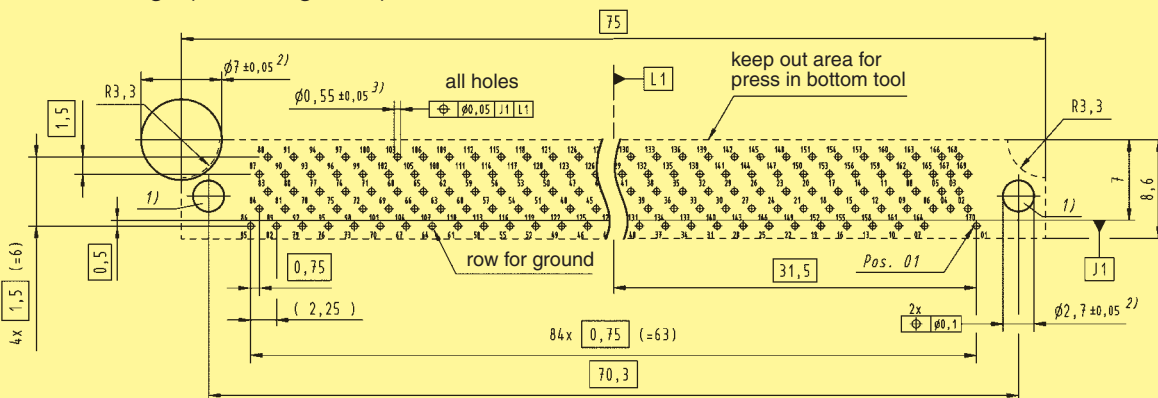

Dimensions [mm]

Technical characteristics

Design according PICMG 3.0 R2.0

Total number of contacts 30, max. 34
 Power contacts 8
 Signal contacts 22, max. 26

Clearance and creepage distance between contacts

Within group 5–16 0.7 mm min.
 Within group 17–24 2.5 mm min.
 25 to 26 5.5 mm min.
 Within group 27–34 1.4 mm min.
 13–16 to 17–20 3.0 mm min.
 21–24 to 25–26 4.0 mm min.
 25–26 to 27–29 2.0 mm min.

Sequential contact engagement

1st 25, 26, 28, 29, 30, 31
 2nd 33
 3rd 5–24, 34
 4th 27, 32

Working current
 Power contacts 16 A
 Signal contacts 1 A

Test voltage
 Contacts 1–16 1000 V_{r.m.s.}
 Contacts 17–34 2000 V_{r.m.s.}

Contact resistance
 Power contacts ≤ 3 mΩ
 Signal contacts ≤ 10 mΩ

Insulation resistance ≥ 10⁸ Ω

Temperature range -55 °C ... +125 °C
 Durability 250 mating cycles

Termination technique Press-in termination
 Mating force 67 N max.
 Withdrawal force 67 N max.

Materials

Moulded parts PBT, glass-fibre filled, UL 94-V0
 Contacts Copper Alloy
 Contact surface Selectively gold plated

Packaging Card box (other packaging on request)

**Available
Q2 / 2007**

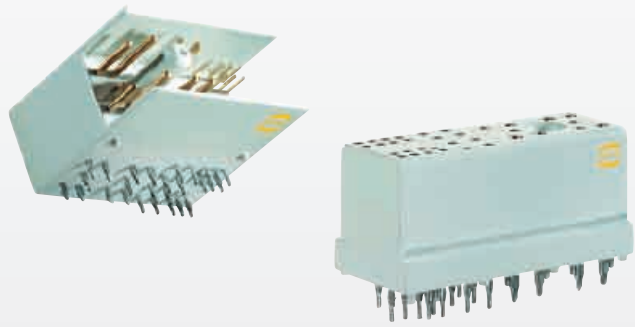

Identification	No. of contacts	Contact length [mm] termination side	Part number
Power connector for AdvancedTCA®, male	30	4.1	16 32 030 1101 000
Power connector for AdvancedTCA®, female	30	5.3	16 31 030 1201 000

Male connector

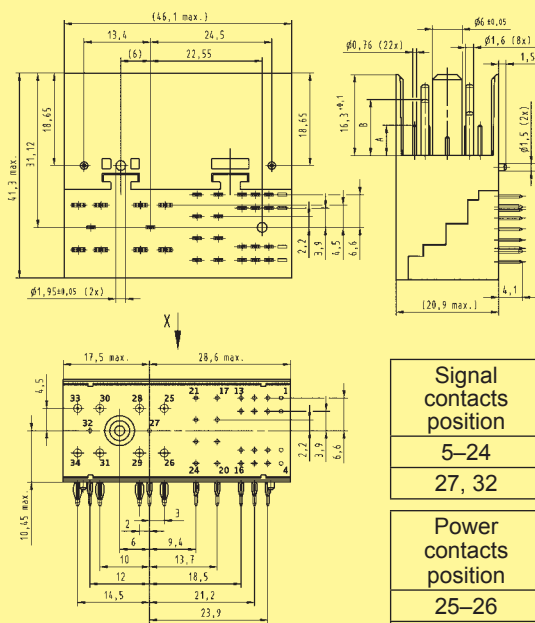

Female connector

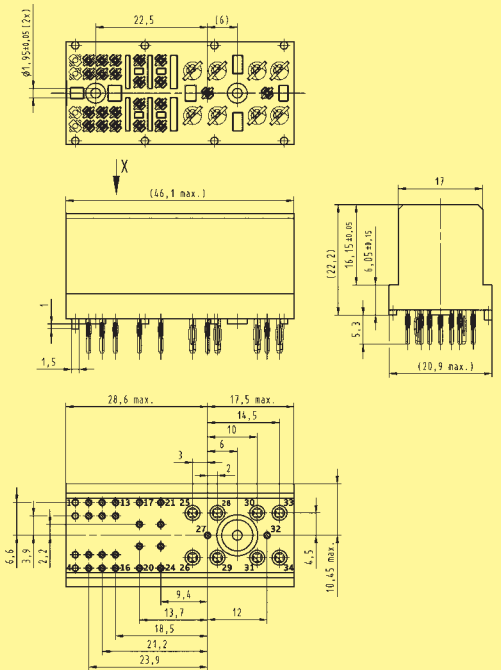

Signal contacts position	Dimension A
5–24	6.1
27, 32	3.8
Power contacts position	Dimension B
25–26	14.3
28–31	14.3
33	11.3
34	8.8

Board drillings

view X

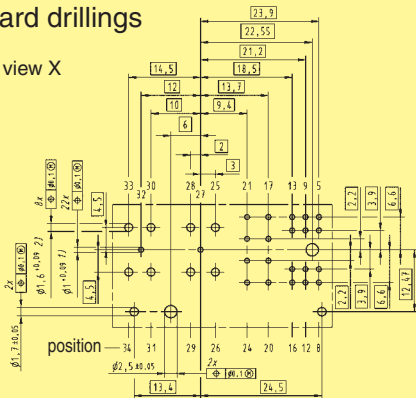

view X

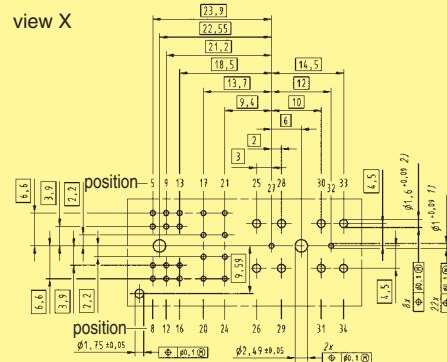

- recommended drill hole diameter: $\varnothing 1.15 \pm 0.025$ mm
through hole diameter (after plating): $\varnothing 1.0 + 0.09$ mm
- recommended drill hole diameter: $\varnothing 1.75 \pm 0.025$ mm
through hole diameter (after plating): $\varnothing 1.6 + 0.09$ mm

Technical characteristics

Design according PICMG MTCA.0 R1.0
(RoHS compliance)

Number of contacts 170
Contact spacing 0.75 mm
Clearance and creepage distance between contacts 0.1 mm min.

Working current of power contacts as defined in MTCA.0 spec. 1.52 A @ 70 °C
max. 30 °C temp. rise
Test voltage 80 V_{r.m.s.}
Contact resistance 25 mΩ max.
Insulation resistance 10 MΩ

Nominal differential impedance 100 Ω ± 10 %
Near end crosstalk (pair-to-pair) @ 30 ps risetime

basic-to-basic	< 0.5 %
basic-to-extended	< 0.2 %
diagonal	< 0.1 %
multiline	< 2.0 %

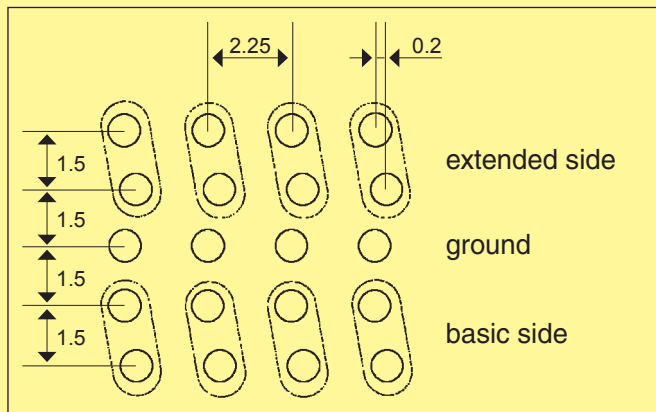

Differential propagation delay

Basic side:	75 ps
Extended side:	75 ps

Differential skew

Between basic and extended side:	± 2 ps
Within basic and extended side:	± 2 ps

Temperature range -55 °C ... +105 °C
Durability as per MTCA.0 spec. 200 mating cycles

Termination technique Press-in termination
Mating force 100 N max.
Withdrawal force 65 N max.

Materials

Moulded parts Liquid Crystal Polymer (LCP), UL 94-V0
Contacts Copper Alloy
Contact surface Palladium nickel plated

Packaging Card box (other packaging on request)

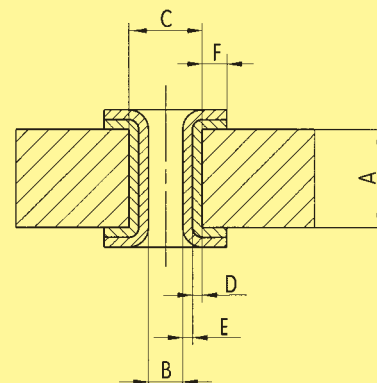

Plated through hole recommendations		
A	pcb thickness	min. 1.4 mm
B	Plated hole-Ø	0.55 ± 0.05 mm
C	Hole-Ø	0.64 ± 0.01 mm
D	Cu	min. 25 µm
E	Plating	- min. 0.8 µm chem. Sn - 0.05 - 0.12 µm Au over 3 - 7 µm Ni - 0.1 - 0.3 µm Ag
F	Pad width	min. 0.15 mm

Technical characteristics

Design according	PICMG MTCA.0 R1.0 (RoHS compliance)	Temperature range	-55 °C ... +105 °C
		Durability	200 mating cycles
		Termination technique	Press-in termination
		Mating force	145 N max.
		Withdrawal force	110 N max.
Total number of contacts	96	Materials	
Power contacts	24	Moulded parts	PBT, glass-fibre filled, UL 94-V0
Signal contacts	72	Contacts	Copper Alloy
Sequential contact engagement		Contact surface	
1st	Power 4–11	Module version	Power contacts: selectively gold plated
2nd	Power 1–3, power 12–24		Signal contacts: selectively palladium nickel plated
3rd	Signal A2–H9		
4th	Signal A1	Backplane version	Selectively palladium nickel plated
Working current		Packaging	Card box (other packaging on request)
Power contacts	9.3 A @ 80 % derating acc. IEC 60512 and 70 °C ambient temperature and 30 °C temperature rise		
Signal contacts	1 A @ 80 % derating acc. IEC 60512 and 70 °C ambient temperature		
Contact resistance			
Power contacts	≤ 10 mΩ		
Signal contacts	≤ 35 mΩ		
Insulation resistance	≥ 10 ⁸ Ω		
Insulation resistance (after moisture)	≥ 10 ⁷ Ω		

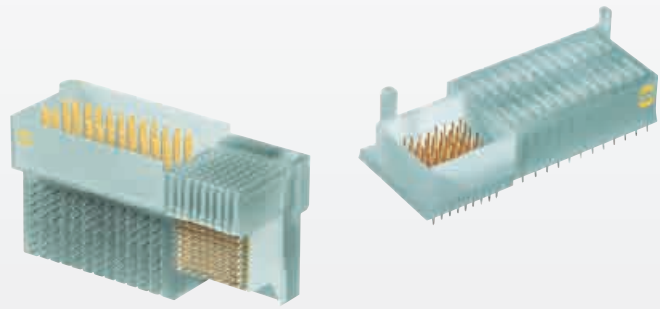

Identification	No. of contacts	Contact length [mm] termination side	Part number
Power output connectors for MicroTCA™			
module version	96	2.8	16 34 096 1101 000
backplane version	96	3.7	16 33 096 1201 000

Module version

Backplane version

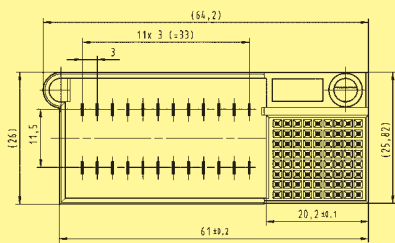

view X

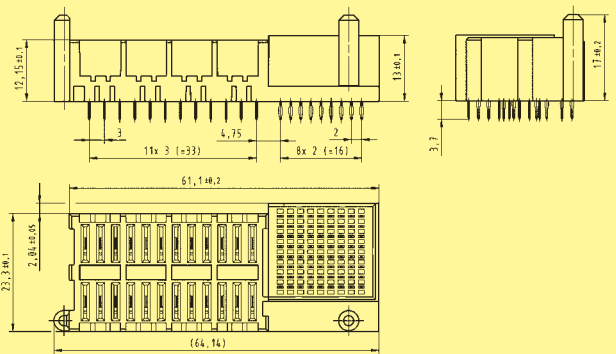
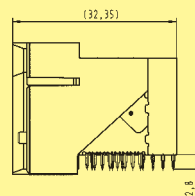

Board drillings

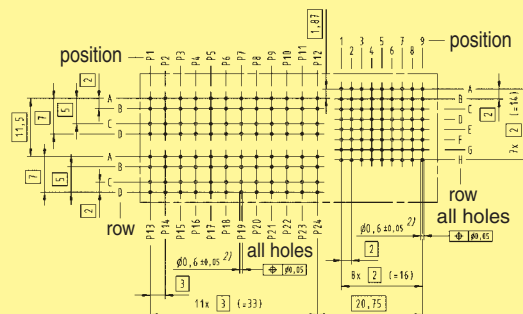
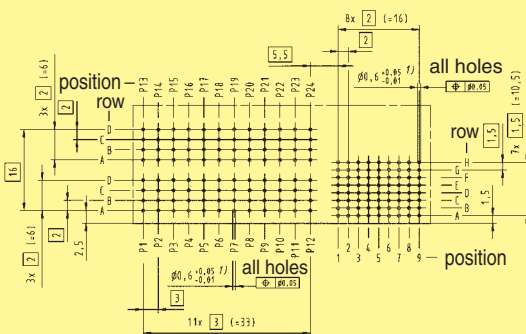

1) recommended drill hole diameter: $\varnothing 0.7 \pm 0.02$ mm
through hole diameter (after plating): $\varnothing 0.6 \pm 0.05$ mm

2) recommended drill hole diameter: $\varnothing 0.7 \pm 0.02$ mm
through hole diameter (after plating): $\varnothing 0.6 \pm 0.05$ mm

For a reliable and safe press-in process HARTING has developed a special tooling system. Each tooling is adapted to the special requirements of the individual connector range, thus a good handling and quick adjustment is guaranteed.

The different demands of the system designs will be covered from the highly adaptable tooling system for AdvancedTCA® or MicroTCA™ with the following options:

- Guiding of the connector and alignment of the top and the bottom tool
- Guiding of the pcb and alignment of the top and the bottom tool

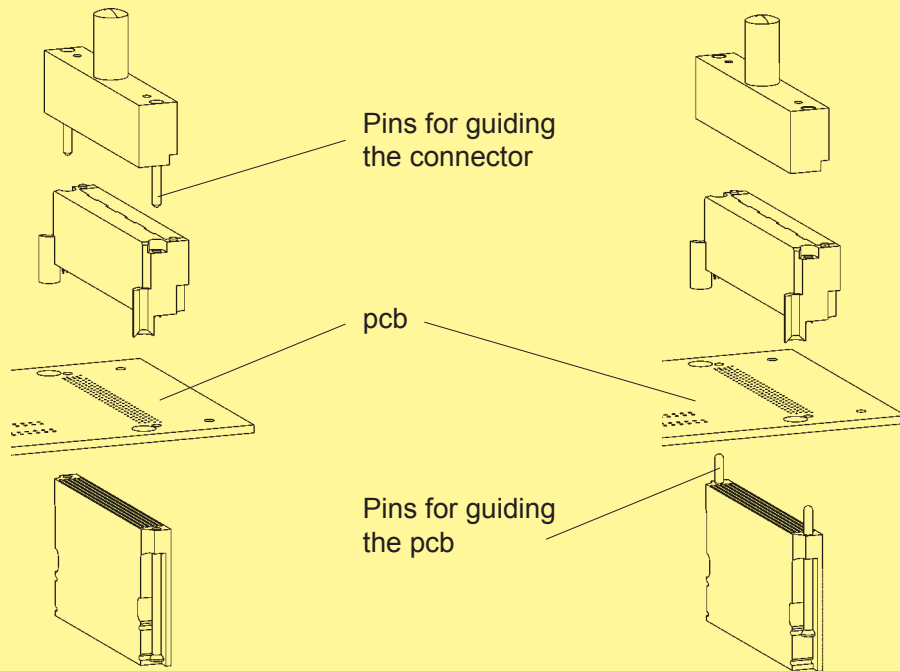

Example for different options to guide connector or pcb.

Top tool for AdvancedTCA® B+

16 99 000 0001 000

Bottom tool for AdvancedTCA® B+

16 99 000 0002 000

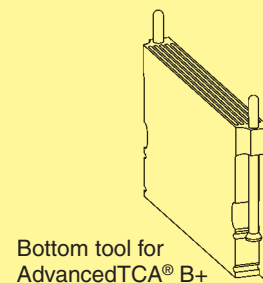
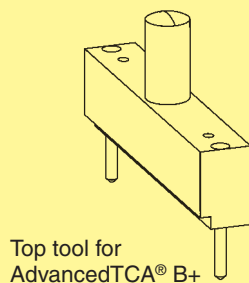

Top tool for MicroTCA™

16 99 000 0003 000

Bottom tool for MicroTCA™

16 99 000 0004 000

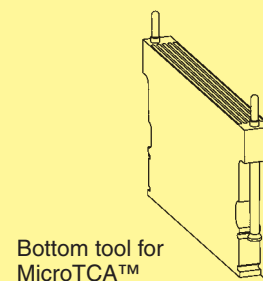
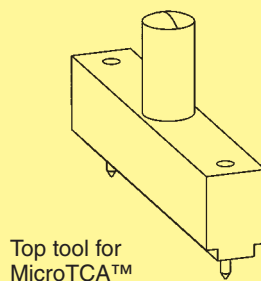

Removal tool for AdvancedTCA® B+

16 99 000 0005 000

Repair pliers for MicroTCA™

16 99 000 0006 000

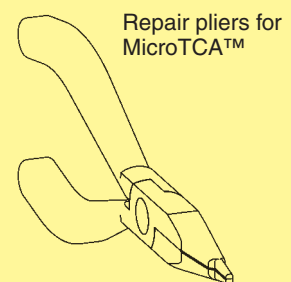
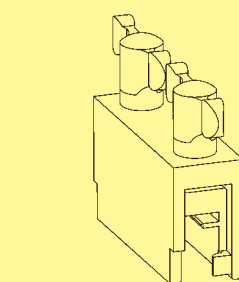

Identification	Part No.	Drawing	Dimensions in mm
Hand bench press	09 99 000 0201		<p>Technical characteristics</p> <p>Working stroke 25 mm</p> <p>Press force 15 kN max.</p> <p>Hole \varnothing in the ram \varnothing 10 mm</p> <p>Net weight approx. 23 kg</p>
Pneumatic press 40 kN	09 99 000 0282		<p>Technical characteristics</p> <p>Total stroke 48 mm</p> <p>Working stroke 0-6 mm</p> <p>Press force 40 kN max.</p> <p>Air pressure 6 bar</p> <p>Hole \varnothing in the ram \varnothing 10 mm</p> <p>Net weight 136 kg</p> <p>Power supply 110 V / 220 V AC</p>
CPM <i>prestige</i>	09 89 040 0000		<p>Technical characteristics</p> <p>Drive electro-mechanical, servo</p> <p>Press-in force 100 kN</p> <p>max. pcb dimensions 600 x 1000 mm</p> <p>Floor space 1200 x 1150 mm</p> <p>Weight 980 kg</p> <p>Power supply 208 / 380 / 400 / 415 V</p> <p>Consumption < 1 kW</p> <p>Colour on request</p>
Adaptor for height compensation ¹⁾	09 99 000 0279		
Guide frame with base plate Standard type for pcb size x = 123,5 - 309,5 mm	09 99 000 0244		
Long type ²⁾ for pcb size x = 123,5 - 668,5 mm	09 99 000 0261		
Base plate	09 99 000 0255		

¹⁾ suitable for 09 99 000 0282 and all CPM machines
²⁾ not suitable for hand bench press

HARTING offers signal integrity support to the end customers. We provide simulation models and evaluation kits with our products for signal integrity investigations. The evaluation kits are assembled with SMA's to connect them directly with the measurement instruments. The benefit is that the customer saves time and costs for pre-evaluation of the connector. We offer test boards suitable for the connector evaluation itself and have built reference backplanes and test cards for measurements within applications like VME, CompactPCI®, AdvancedTCA® and MicroTCA™. Reference structures and well established measurement techniques allow a full de-embedding of the propagation characteristics of the interconnect itself for test and verification. Furthermore we developed several high-speed test backplane with different connector areas and pcb design topologies. We

can provide footprint and routing recommendations for our products. A variety of testboards, simulation models and further technical data for different products are available on request.

HARTING is also an active member in standardization groups like VITA, PICMG, OBSAI and supports sub-committees for new interconnect solutions. We are in close cooperation with customers, universities and industrial partners for research activities.

Signal integrity capabilities

- Simulation and modeling
- Measurement and verification
- Test fixture & reference backplane design
- Design-in support

Simulation and modeling

Capability to perform full 3D-FEM simulations of the CAD-geometry with different well established tools like CST Microwave Studio and Ansoft HFSS. Post-processing of the data for field-distribution and full S-parameter and time-domain analysis within the software packages themselves and additional Matlab tools.

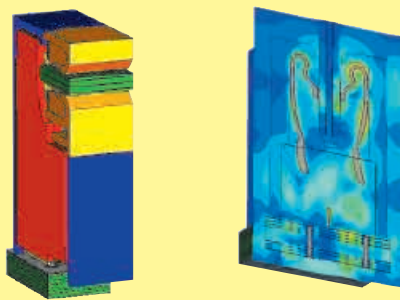

For SPICE-modeling, impedance calculation and field distribution analysis of the geometry S-parameter models are used in combination with static 3D-FEM, 2D-FEM and planar field solvers depending on the desired bandwidth of the signal. These models are used as library parts for channel simulations including particular chip, trace, vias and connector subcircuits. Eye-diagram, S-parameter and waveform analysis of the entire channel are performed with tools like HSPICE and ADS (Advanced Design System).

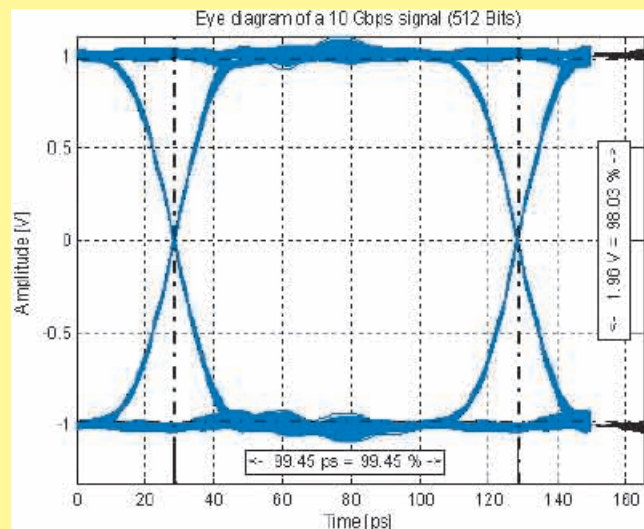
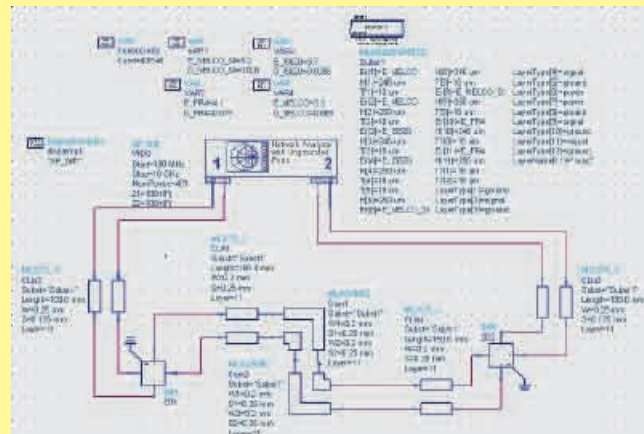

Time-domain measurements

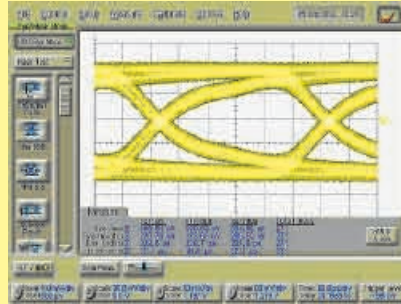

Parameters:

- Characteristic impedance
- Propagation delay
- Rise time degradation
- Reflection
- Crosstalk
- Eye-diagram and mask-test
- Bit-error rate testing (BERT) up to 12.5 Gbps per differential line

Frequency-domain measurements

Parameters:

- 4 port S-parameter analysis (up to 40 GHz)
- Insertion- and return loss, crosstalk, VSWR
- Fourier-transformation, gating, error-location
- PLTS software to calculated time-domain data, eye-diagrams, etc.



Test fixture & reference backplane design

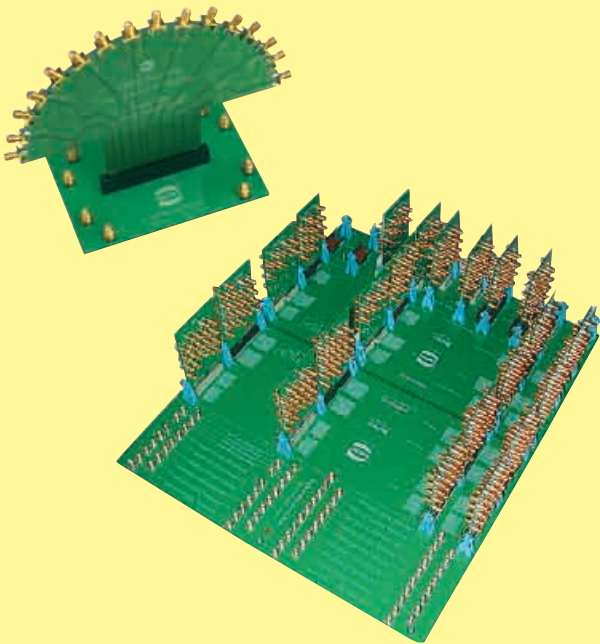

Design-in support

- Customized pcb design close to the real application
- Footprint and routing recommendations
- Full measurement characterization and test report
- Simulation models

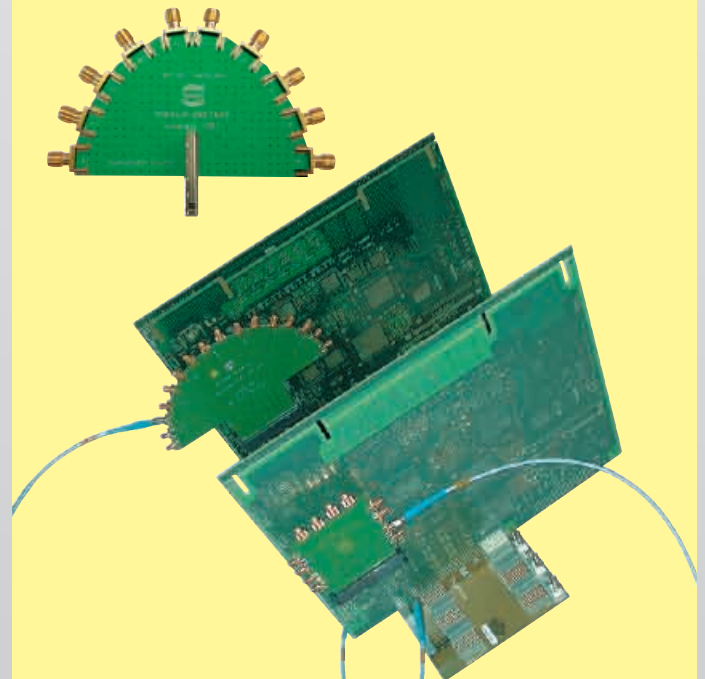

Please send me further information:

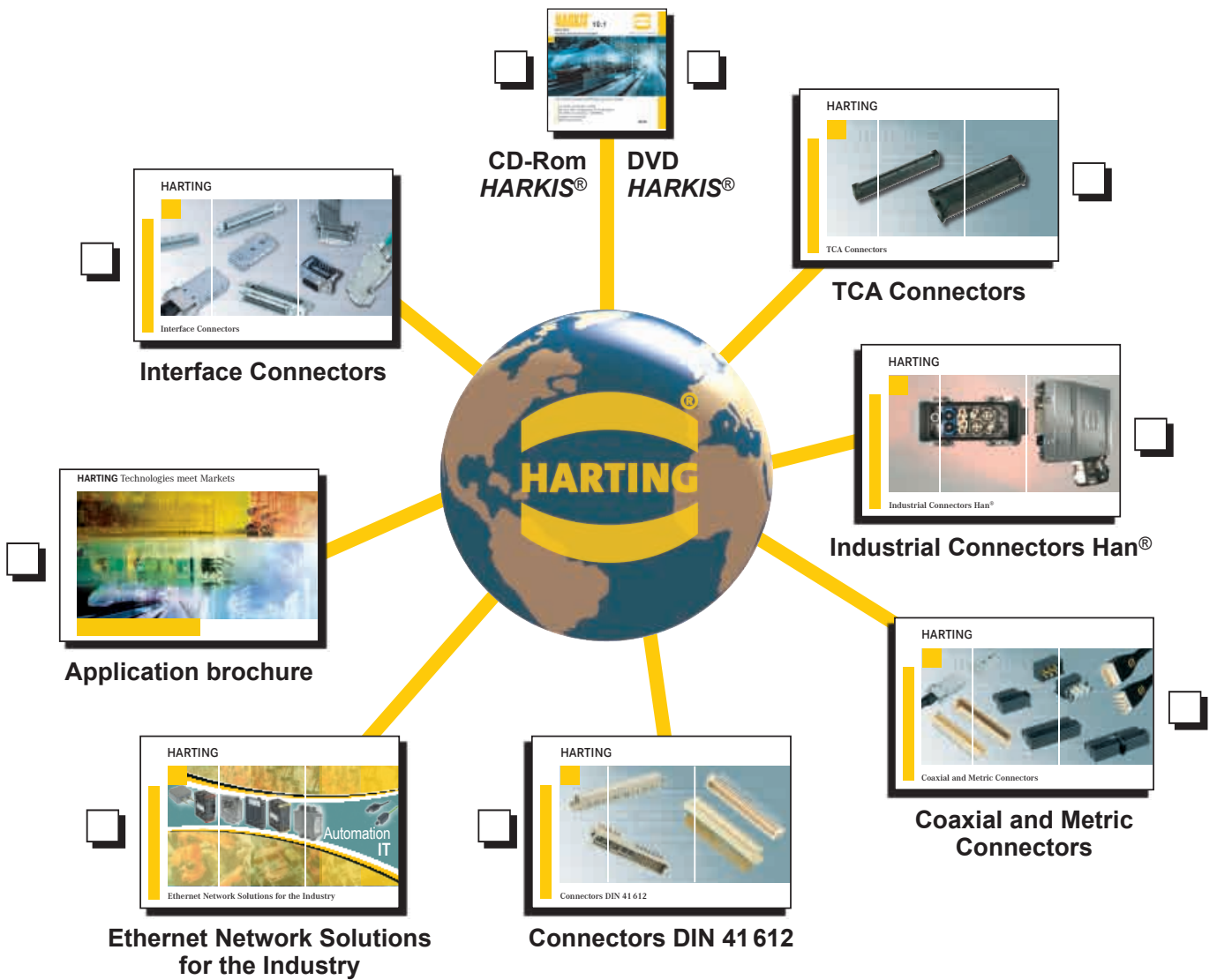

Sender: _____

Company: _____

Street: _____

Department: _____

Postcode/Town: _____

Name: _____

Country: _____

Prenome: _____

Phone: _____

Function: _____

Fax: _____

E-mail: _____

Please send it by post or fax to your local HARTING Representatives (see page addresses) or visit us under www.HARTING.com.

Production plants – worldwide



Espelkamp / Germany – Plant 1



Espelkamp / Germany – Plant 2



Espelkamp / Germany – Plant 3



Espelkamp / Germany – Plant 4



Espelkamp / Germany – Plant 5

Representatives – worldwide



Argentina

Condell Electronica
Julian Agüero 3355
(1605) Munro, Pcia. de Buenos Aires
Phone + Fax +54 11 4762.0118
E-Mail: mediavicondel@arnet.com.ar

Australia

ADILAM Electronics Pty. Ltd.,
14 Nicole Close, North Bayswater
3153 Victoria
Phone +61 3 9737 4900
Fax +61 3 9737 4999
E-Mail: mark.c@adilam.com.au
Internet: www.adilam.com.au

Bulgaria

COMET ELECTRONICS
16, Tsar Samuil Str., BG-1000 Sofia
Phone +359-2-9155800
Fax +359-2-9540384
E-Mail: office@comet.bg
Internet: www.comet.bg

Denmark

Knud Wexøe A/S
Skaettekaeret 11, P.O. Box 152
DK-2840 Holte
Phone +45 45 46 58 00
Fax +45 45 46 58 01
E-Mail: wexoe@wexoe.dk
Internet: www.wexoe.dk

Finland

INTOTEL OY
Kutojantie 4, 02630 Espoo, Finland
P.O. Box 125, 02631 Espoo, Finland
Phone +358-9-521 300
Fax +358-9-755 3581
E-Mail: into@intotel.fi
Internet: www.intotel.fi

Hungary

Mile Kft.
Mádi u. 52, H-1104 Budapest
Phone +36-1-431-9800
Fax +36-1-431-9817
E-Mail: milekft@mile-kft.hu
Internet: www.mile-kft.hu



Zhuhai / China



Northampton / Great Britain



Biel / Switzerland



Sibiu / Romania



Elgin / USA

Representatives – worldwide



Israel
COMTEL
Israel Electronics Solutions Ltd.
Bet Hapamon, 20 Hataas st.
P.O.Box 66
Kefar-Saba 44425
Phone +972-9-7677240
Fax +972-9-7677243
E-Mail: sales@comtel.co.il
Internet: www.comtel.co.il

Poland
Soyter Sp. z o. o.
ul. Warszawska 3
05-082 Warszawa - Stare Babice
Phone +48 22 722 0 685
Fax +48 22 722 0 550
E-Mail: handlowy@soyter.com.pl
Internet: www.soyter.com

Ukraine
Incomtech Ltd.
4 Lermontovskaya St., UA-04050 Kiev
Phone +380-44-213-3641
Fax +380-44-213-3814
E-Mail: eletech@incomtech.com.ua
Internet: www.incomtech.com.ua

South-Africa
Cabcon Technologies (PTY)Ltd
P.O. Box 4603, Dalpark
1543 Gauteng
Phone +27 1184533258
Fax +27 118454077
E-Mail: cabcon@mweb.co.za

Subsidiary companies – worldwide



Austria
HARTING Ges. m. b. H.
Deutschstraße 3, A-1230 Wien
Phone +43 1/6 1621 21
Fax +43 1/6 1621 21-21
E-Mail: at@HARTING.com

Czech Republic
HARTING spol. s.r.o.
Mlýnská 2, 160 00 Praha 6
Phone +420 220 380 460
Fax +420 220 380 461
E-Mail: cz@HARTING.com
Internet: www.HARTING.cz

Great Britain
HARTING Ltd., Caswell Road
Brackmills Industrial Estate
GB-Northampton, NN4 7PW
Phone +44 16 04/76 66 86, 82 75 00
Fax +44 16 04/70 67 77
E-Mail: gb@HARTING.com
Internet: www.HARTING.co.uk

Belgium
HARTING N.V./S.A.
Z.3 Doornveld 23, B-1731 Zellik
Phone +32 2/4 66 01 90
Fax +32 2/4 66 78 55
E-Mail: be@HARTING.com

Finland
HARTING Oy
Teknobulevardi 3-5, PL 35
FI-01530 Vantaa
Phone +358 9 350 873 00
Fax +358 9 350 873 20
E-Mail: fi@HARTING.com

Hong Kong
HARTING (HK) Limited
Regional Office Asia Pacific
4208 Metroplaza Tower 1
223 Hing Fong Road
Kwai Fong, N. T., Hong Kong
Phone +8 52/24 23 - 73 38
Fax +8 52/24 80 - 43 78
E-Mail: ap@HARTING.com
Internet: www.HARTING.com.hk

Brazil
HARTING Ltda.
Av. Dr. Lino de Moraes, Pq. Jabaquara, 255
CEP 04360-001 - São Paulo - SP - Brazil
Phone +55 11/50 35 - 00 73
Fax +55 11/50 34 - 47 43
E-Mail: br@HARTING.com
Internet: www.HARTING.com.br

France
HARTING France
181 avenue des Nations, Paris Nord 2
BP 66058 Tremblay en France
F-95972 Roissy Charles de Gaulle
Cédex
Phone +33 1 49 38 34 00
Fax +33 1 48 63 23 06
E-Mail: fr@HARTING.com

China
Zhuhai HARTING
Limited Shanghai branch
Room 5403, 300 Huaihai Zhong Road
Hong Kong New World Tower
Luwan District, P.R.C
Shanghai 200021, China
Phone +86 21 - 63 86 22 00
Fax +86 21 - 63 86 86 36
E-Mail: cn@HARTING.com

Germany
HARTING Deutschland
GmbH & Co. KG
Postfach 2451 · D-32381 Minden
Simeons carré 1 · D-32427 Minden
Phone (05 71) 88 96 - 0
Fax (05 71) 88 96 - 2 82
E-Mail: de@HARTING.com
Internet: www.HARTING.com

Hungary
HARTING Eastern Europe GmbH
Magyarországi Kereskedelmi
Képviselő
1119 Budapest
Fehérvári út 89-95, II. emelet 217/A.
Phone +36-1-205 3464
Fax +36-1-205 3465
E-Mail: hu@HARTING.com
Internet: www.HARTING.hu

India

HARTING India Private Limited
No. D, 4th Floor, 'Doshi Towers'
No. 156 Poonamallee High Road,
Kilpauk, Chennai 600 010,
Tamil Nadu, Chennai
Phone +91-44-4356 0415/6
Fax +91-44-4356 0417
E-Mail: in@HARTING.com
Internet: www.HARTING.com

Italy

HARTING SpA
Via Dell' Industria 7
I-20090 Vimodrone (Milano)
Phone +39 02/25 08 01
Fax +39 02/2 65 05 97
E-Mail: it@HARTING.com

Japan

HARTING K. K.
Yusen Shin-Yokohama 1 Chome
Bldg., 2F
1-7-9, Shin-Yokohama
Kohoku-ku, Yokohama
222-0033 Japan
Phone +81 45 476 3456
Fax +81 45 476 3466
E-Mail: jp@HARTING.com
Internet: www.HARTING.co.jp

Korea

HARTING Korea Limited
#308 Leaders Bldg., 342-1,
Yatap-dong, Bundang-gu,
Sungnam-City, Kyunggi-do,
463-828, Korea
Phone +82-31-781-4615
Fax +82-31-781-4616
E-Mail: kr@HARTING.com

Netherlands

HARTING B.V.
Larenweg 44
NL-5234 KA 's-Hertogenbosch
Postbus 3526
NL-5203 DM 's-Hertogenbosch
Phone +31 73/6 41 04 04
Fax +31 73/6 44 06 99
E-Mail: nl@HARTING.com

Norway

HARTING A/S
Østensjøveien 36, N-0667 Oslo
Phone +47 22/70 05 55
Fax +47 22/70 05 70
E-Mail: no@HARTING.com

Poland

HARTING Eastern Europe GmbH
Przedstawicielstwo w Polsce
ul. Kamieńskiego 201-219
51-126 Wrocław
Phone +48 71-352 81 71
Phone +48 71-352 81 74
Fax +48 71-320 74 44
E-Mail: pl@HARTING.com
Internet : www.HARTING.pl

Portugal

HARTING Iberia, S. A.
Avda. Josep Tarradellas, 20-30, 4º 6ª
E-08029 Barcelona
Phone +351.219.673.177
Fax +351.219.678.457
E-Mail: es@HARTING.com

Russia

HARTING ZAO
ul. Tobolskaja 12, Saint Petersburg
194044 Russia
Phone +7/8 12/3 27 64 77
Fax +7/8 12/3 27 64 78
E-Mail: ru@HARTING.com
Internet: www.HARTING.ru

Singapore

HARTING Singapore Pte Ltd.
No. 1 Coleman Street
#B1-21 The Adelphi
Singapore 179803
Phone +656 2 25 52 85
Fax +656 2 25 99 47
E-Mail: sg@HARTING.com

Spain

HARTING Iberia S.A.
Josep Tarradellas 20-30 4º 6ª
E-08029 Barcelona
Phone +34 933 638 475
Fax +34 934 199 585
E-Mail: es@HARTING.com

Sweden

HARTING AB
Gustavslundsvägen 141 B 4tr
167 51 Bromma
Phone +46 8/4 45 71 71
Fax +46 8/4 45 71 70
E-Mail: se@HARTING.com

Switzerland

HARTING AG
Industriestrasse 26
CH-8604 Volketswil
Phone +41 44 908 20 60
Fax +41 44 908 20 69
E-Mail: ch@HARTING.com

Taiwan

HARTING R.O.C. Limited
Room 6, 10 Floor, No. 171
Sung-Te-Road
Taipei, 110 Taiwan
Phone +886-2-23 46-31 77
Fax +886-2-23 46-26 90
E-Mail: tw@HARTING.com

USA

HARTING Inc. of North America
1370 Bowes Road, Elgin
Illinois 60123
Phone +1 (877) 741-1500 (toll free)
Fax +1 (866) 278-0307 (Inside Sales)
Fax +1 (847) 717-9420 (Sales and Marketing)
E-Mail: us@HARTING.com
Internet: www.HARTING-USA.com

Eastern-Europe

HARTING Eastern Europe GmbH
Bamberger Straße 7
D-01187 Dresden
Phone +49 351 / 4361760
Fax +49 351 / 4361770
E-Mail:
Eastern.Europe@HARTING.com

Other countries

HARTING
Electronics GmbH & Co. KG
Postfach 14 33, D-32328 Espelkamp
Phone +49 57 72/47-97 200
Fax +49 57 72/47-7 77
E-Mail: electronics@HARTING.com

Distributors – worldwide



Farnell InOne

www.farnellinone.com;
in US: Newark InOne:
www.newarkinone.com

FUTURE Electronics

www.futureelectronics.com

RS Components

www.rs-components.com;
in US: Allied Electronics:
www.alliedelec.com

Global Business Unit Electronics



HARTING Electronics
GmbH & Co. KG

P.O.Box 14 33
D-32328 Espelkamp

Phone +49 57 72/47-97 200
Fax +49 57 72/47-7 77

E-Mail: electronics@HARTING.com

Internet: www.HARTING.com



People | Power | Partnership